



**SUBWAY
CERAMICS**

America's Heritage Tilework

Design Guide

WWW.HERITAGETILE.COM

info@heritagetile.com



HERITAGETILE™
WE CARE ABOUT THE CRAFT

Tel: 888-387-3280

Our Mission

Heritage Tile was created out of a need for tilework that embodies the same quality and craftsmanship as period architecture. Every Heritage Tile collection has been carefully designed to reproduce the specific time & place that defines your home to restore its original character and period authenticity. Each Heritage Tile collection offers a complete solution for the period home, with appropriate surface finishes, color palettes, trim and mouldings elements, floor mosaics, decorative designs, and ceramic accessories that define its period style.

Contents

Glaze Palettes	4
Color Variation Chart	17
Our Inspiration	18
Design Resources	26
Products	28
Field Tile & Liners	29
Base Mouldings	30
Surface Trims	32
Radius Trims	35
Quarter Trims	38
Mud Cap Mouldings	40
P - Cap Mouldings	41
Box Cap Mouldings	44
Victoria Cap Mouldings	46
Bevel Mouldings	47
Specialty Field Tile	48
Ceramic Accessories	50
Ceramic Cover Plates	51
Series 15 Large Radius Mouldings	52
Subway Mosaic Design Guide	62
Made-to-Order Patterns	68
Popular Patterns	70
Solid Color Fields	71
Made-to-Order Fonts	77

TRUE CRAFTSMANSHIP

Choose from a wide assortment of color palettes and finishes: classic white glazes, translucent crackle glazes, soft satin glazes, bright gloss glazes, or antiqued crackle glazes.

PERIOD PALETTES

Organized by architectural period palettes, Subway Ceramics offers just the right set of options for your subway tile project. Dial into an aesthetic movement, from the Classic Subway Style to the Bungalow, Cottage, Cosmo or Atomic age to recreate a century of architectural period styles. With a vast array of glazes, the Subway Ceramics collection offers exceptional design versatility to suit any subway tile project.



TIMELESS DESIGN

Realize your design intent with a space that reflects your own personal style, a style that is both fresh and enduring. Avoid the perennial fashions that can impart a dated quality to your work. Rediscover the creative freedom by imaging new renditions of these traditional tile forms.

AUTHENTIC DETAILS

Discover how to create an elegant, 3-dimensional space without the mitered, cut-to-fit look of conventional tile installations. Restore the original character to your period home or devise a place and time for your next hospitality project. Partner with us and we will help you make it happen.



COMPOSING A VICTORIAN STYLE DESIGN

Reproduce a classic Victorian-era design with mouldings, accent liners, trim, and field tile composition we have gathered from historic precedents. Shown below is an example of a complete inside corner transition of a wainscot.

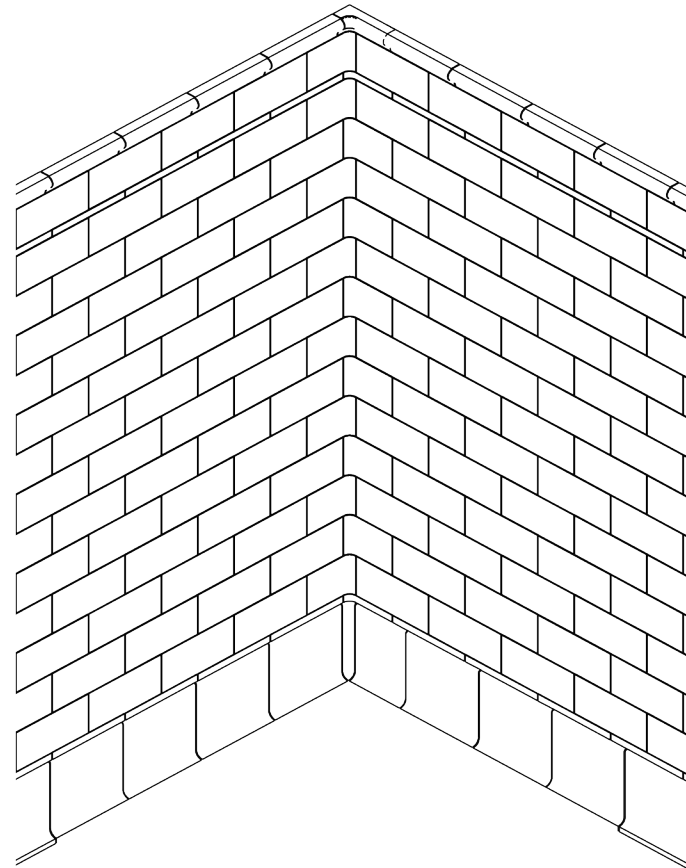

CAP MOULDING

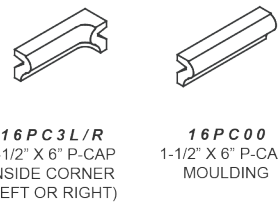

ACCENT LINER

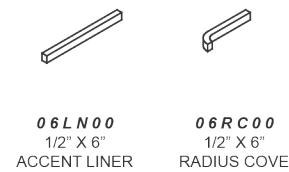

FIELD TILE

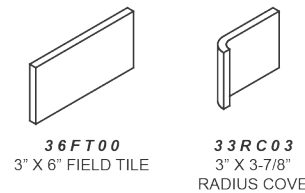

BASE MOULDING

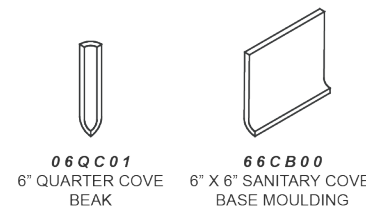

The Classic Subway Tile glaze palette reproduces the classic Victorian-era colors in a deep, translucent finish. Subway tile was originally designed using a gloss white finish on field tile and corner mouldings, but deeper and richer colors were introduced once the style gained popularity in homes and businesses around the USA. Use these glazes as a simple accent through an elegant white field, or create a lavish surface when used as your field glaze. Truly timeless!



10 Gloss White



12 Gloss Bianco



99 Gloss Black



14 Gloss Avalon



11 Gloss Bone



21 Crackle White



15 Satin White

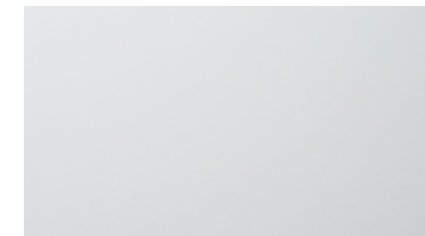

16 Satin Ivory



92 Satin Black

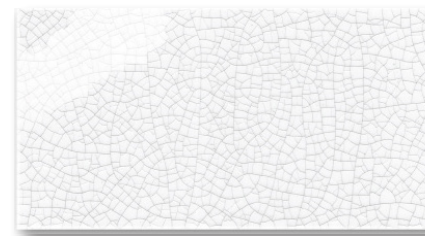

C0 Victoria White

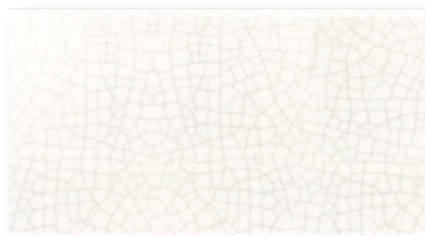

C1 Cottage White

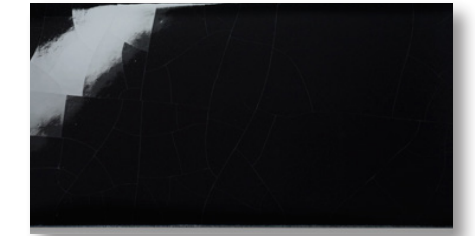

91 Crackle Black



33 Sky Blue



51 Marine Blue



62 Lagoon Blue

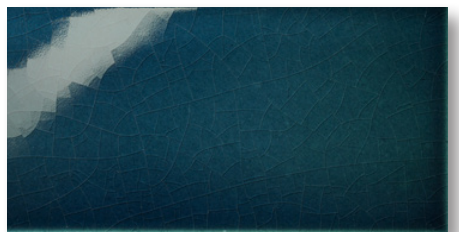

53 Midnight Blue

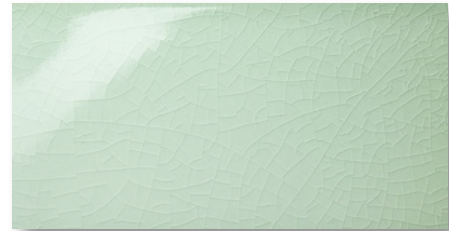

42 Celadon

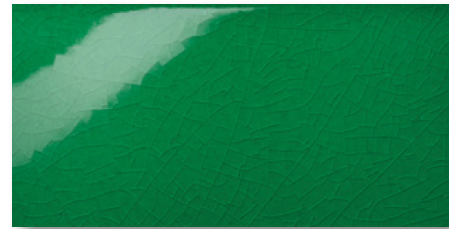

61 Emerald Green

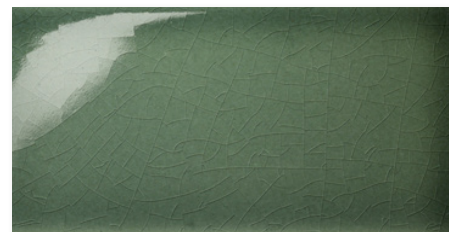

52 Hunter Green



41 Heather Grey



31 Blush

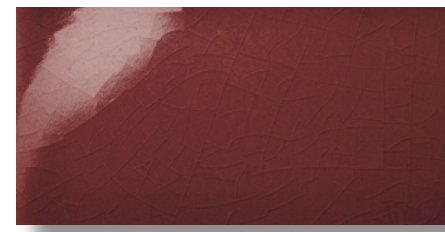

71 Garnett



32 Butter



43 Khaki



63 Ginger



54 Leather



COMPOSING A BUNGALOW STYLE DESIGN

Reproduce a classic Bungalow style design with mouldings, accent liners, trim, and field tile composition we have gathered from historic precedents. Shown below is an example of a complete inside corner transition of a wainscot.

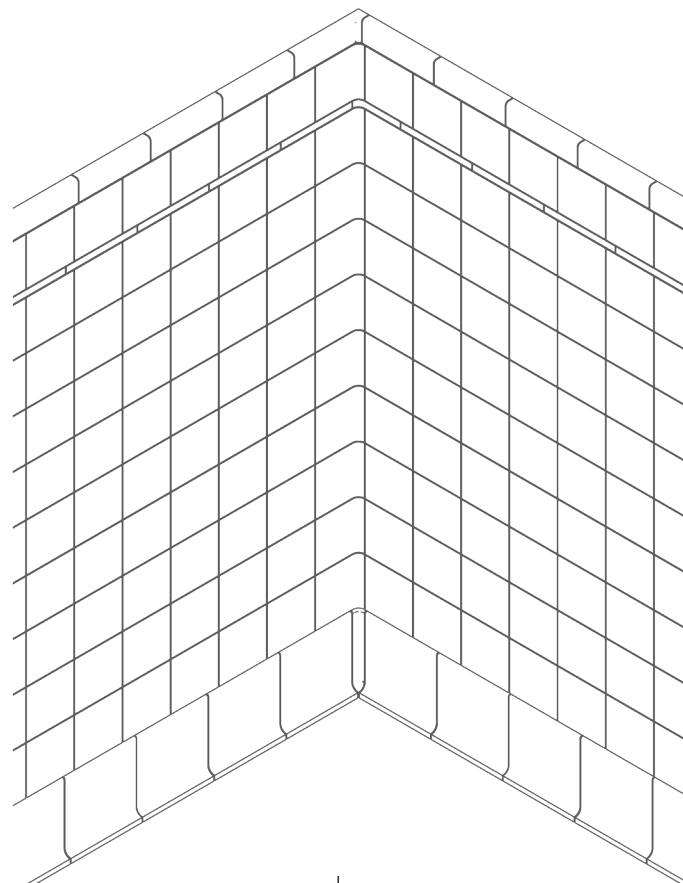

CAP MOULDING

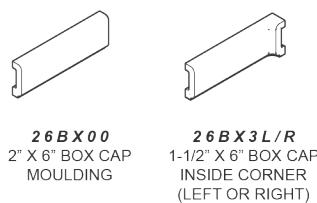

ACCENT LINER

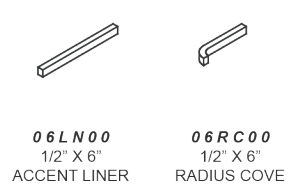

FIELD TILE

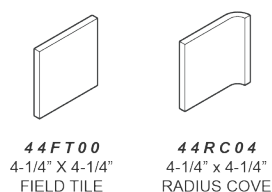

BASE MOULDING

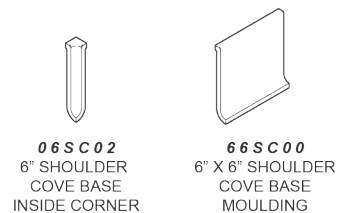

The Bungalow Tile glaze palette includes soft, satin finishes and hues steeped in the Arts & Crafts tradition. Colors like Seafoam, Sunbeam and Tea Rose were inspired by the chinaware sinks and ceramic accessories that we discovered at antique fairs. Add a delicate charm to your space with these historic glazes.



15 Satin White

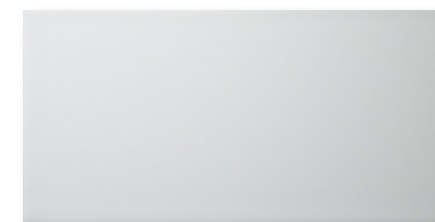

16 Satin Ivory



92 Satin Black

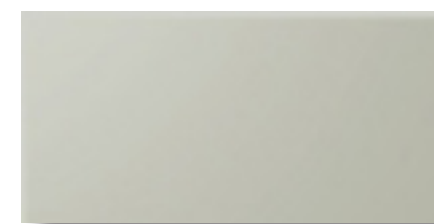

B0 Mockingbird Grey

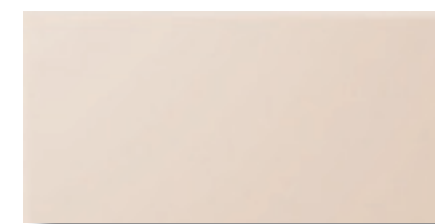

B1 Tea Rose

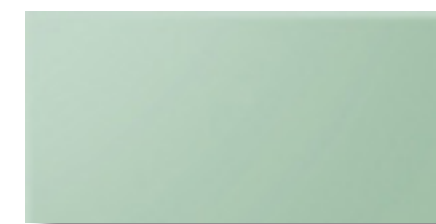

B2 Seafoam Green

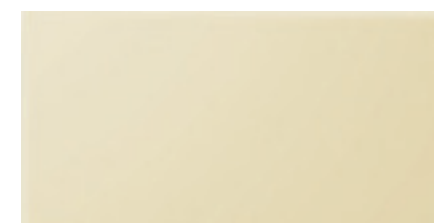

B3 Sunbeam Yellow

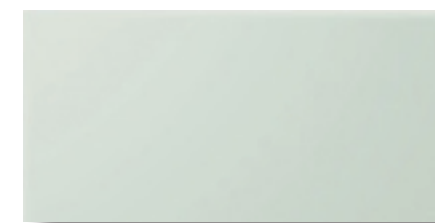

B4 Watercolor Blue



B5 Pinecone Brown

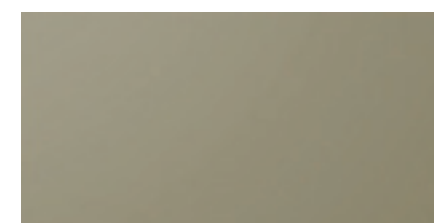

B6 Sageleaf Green

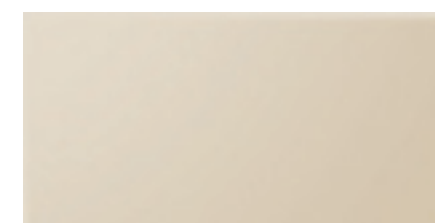

B7 Moonshine



B8 Gunmetal Blue



COMPOSING A COTTAGE STYLE DESIGN

Reproduce a classic Cottage style design with mouldings, accent liners, trim, and field tile composition we have gathered from historic precedents. Shown below is an example of a complete inside corner transition of a wainscot.

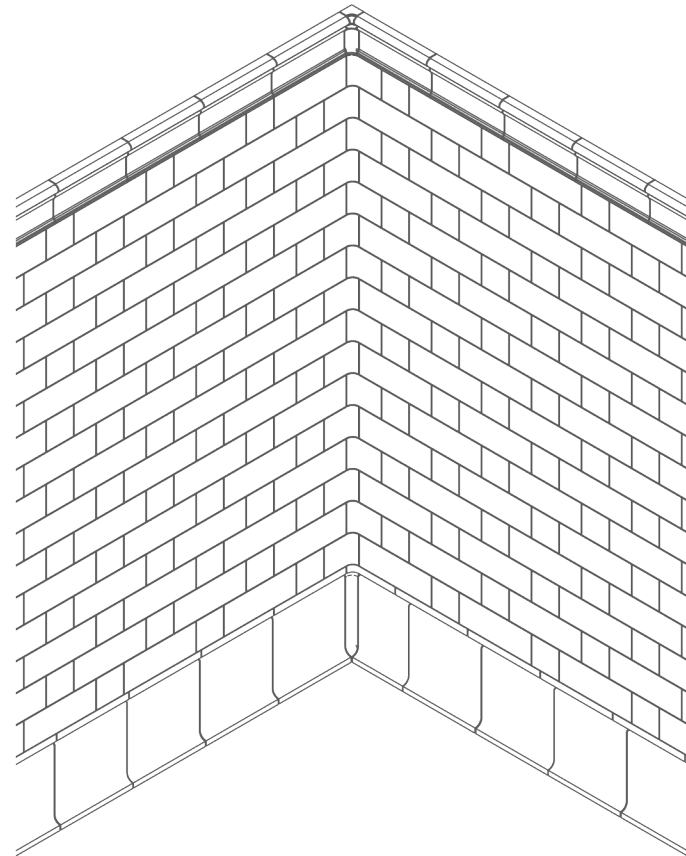

CAP MOULDING

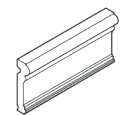

36VC00
3" X 6" VICTORIA CAP
MOULDING



36VC03
3" VICTORIA CAP
INSIDE CORNER

ACCENT LINER



06LN00
1/2" X 6"
ACCENT LINER



06RC00
1/2" X 6"
RADIUS COVE

FIELD TILE

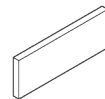

26FT00
2" X 6"
FIELD TILE



22FT00
2" X 2"
FIELD TILE



23RC02
2" X 3-7/8"
RADIUS COVE

BASE MOULDING



06SC02
6" SHOULDER
COVE BASE
INSIDE CORNER

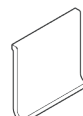

66SC00
6" X 6" SHOULDER
COVE BASE
MOULDING

The unique Cottage Subway Tile palette features a stained satin crackle finish that harmonizes perfectly with your Cottage-style space. These pastel colors add a calm atmosphere to a room, and are beautifully paired with floral accent pieces. Quintessentially charming!



C0 Victorian White

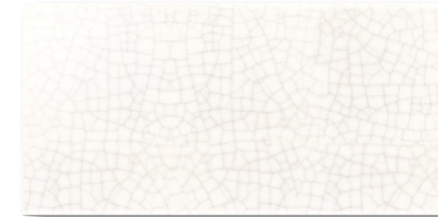

C1 Cottage White



C2 Sweet Cream

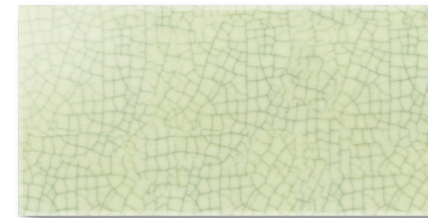

C3 Seaside



C4 Bluebell



C5 Orchid



C6 Oyster

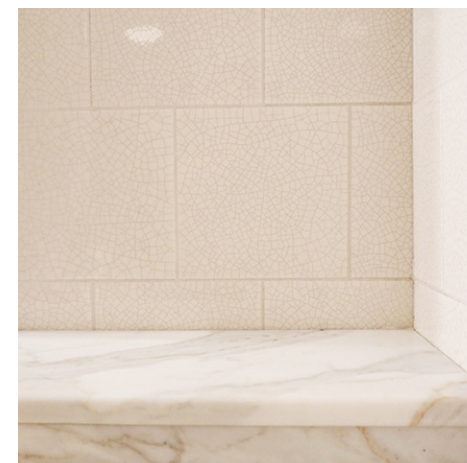

Battery Maritime Building - NYC
6x6 tile in Cottage White



COMPOSING A MID-CENTURY MODERN DESIGN

Reproduce a Mid-Century modern design with mouldings, accent liners, trim, and field tile composition we have gathered from historic precedents. Shown below is an example of a complete inside corner transition of a wainscot.

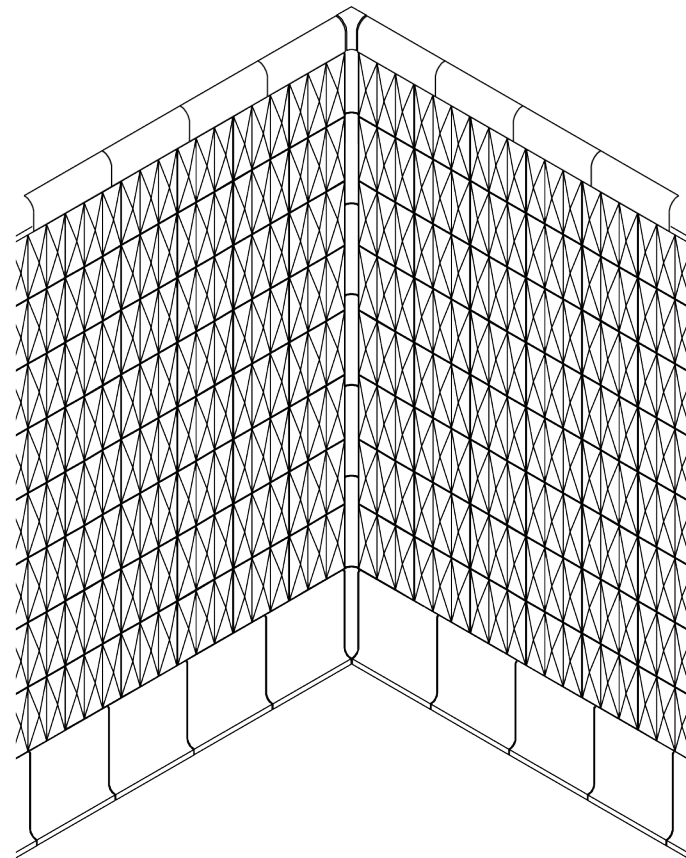

CAP MOULDING

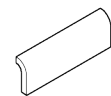

26MC00
2" X 6" MUD CAP
MOULDING



02MC02
2" MUD CAP
INSIDE CORNER

FIELD TILE

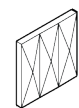

44RT01
4-1/4" X 4-1/4"
DIAMOND PATTERN
FIELD TILE



06QC00
6" QUARTER
COVE

BASE MOULDING



06SC02
6" SHOULDER
COVE BASE
INSIDE CORNER

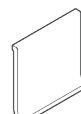

66SC00
6" X 6" SHOULDER
COVE BASE
MOULDING

The Atomic Subway Tile collection extends our timeline to the mid-century period in American architectural design. The collection pays homage to the exuberance of notable American designers with a color palette inspired by the bright hues of 1950's Fiesta ware and the softer shades of Formica Boomerang countertops. A low-luster satin finish delivers a surface with character and energy into your space.

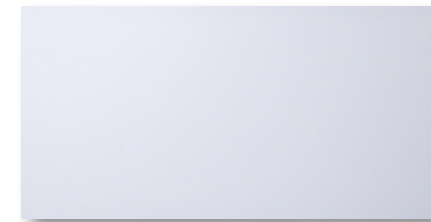

15 Satin White

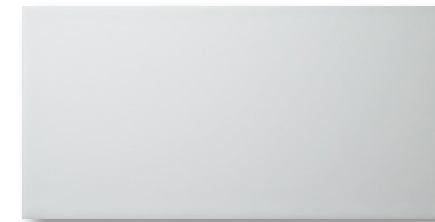

16 Satin Ivory



92 Satin Black

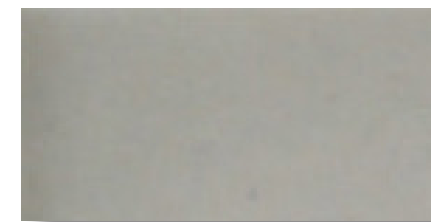

A0 Satin Storm

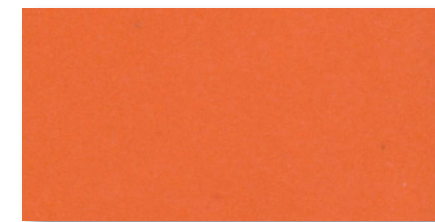

A1 Satin Atomic

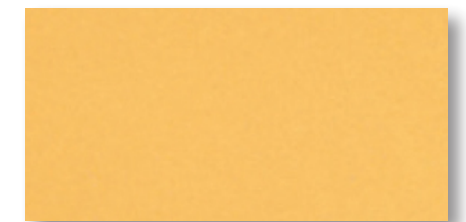

A2 Satin Mango

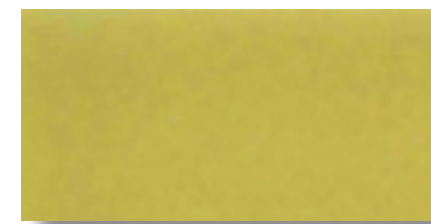

A3 Satin Chartreuse

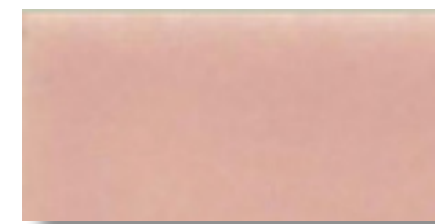

A4 Satin Rose

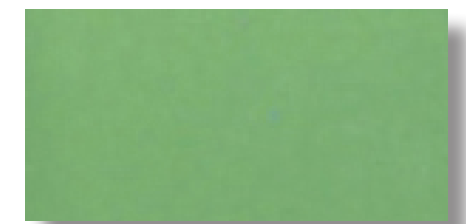

A5 Satin Lucky

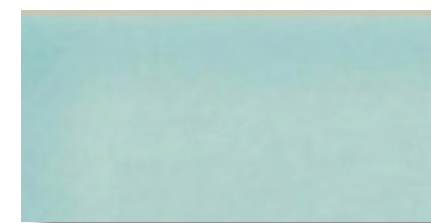

A6 Satin Aqua

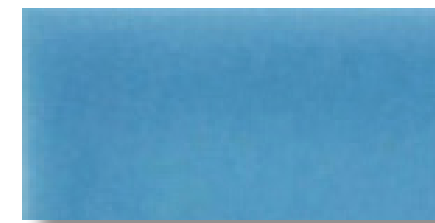

A7 Satin Turquoise

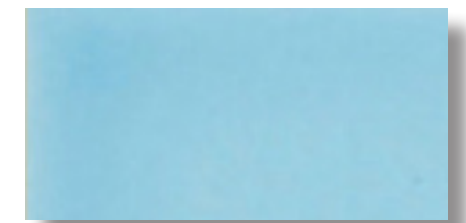

A8 Satin Powder



COMPOSING A COSMOPOLITAN STYLE DESIGN

Reproduce a classic Cosmopolitan style design with mouldings, accent liners, trim, and field tile composition we have gathered from historic precedents. Shown below is an example of a complete inside corner transition of a wainscot.

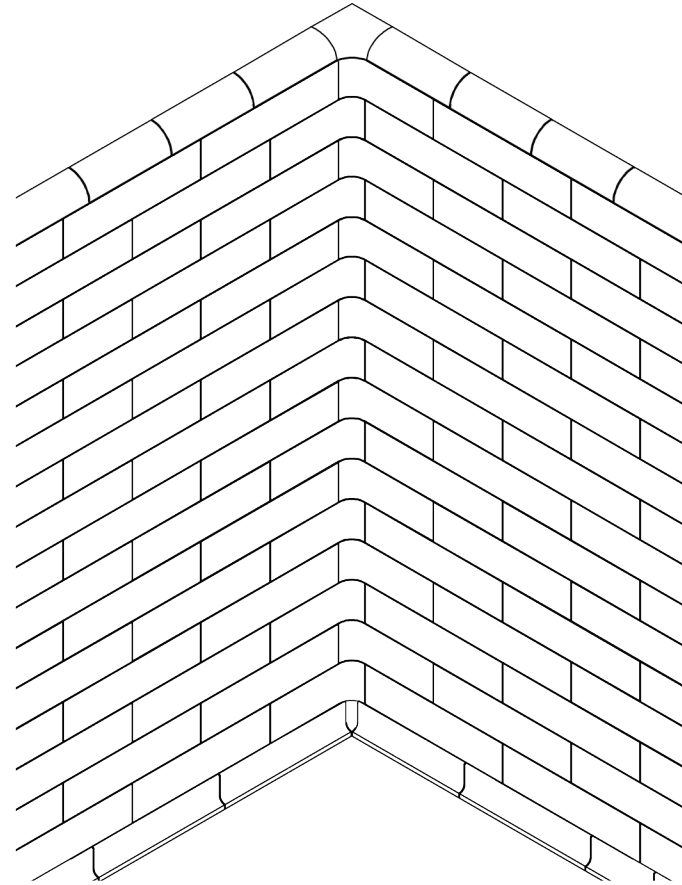

CAP MOULDING

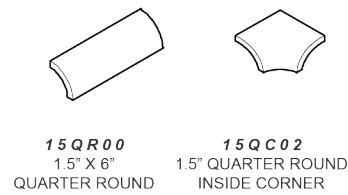

FIELD TILE

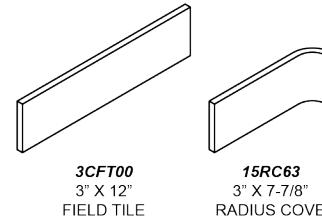

BASE MOULDING

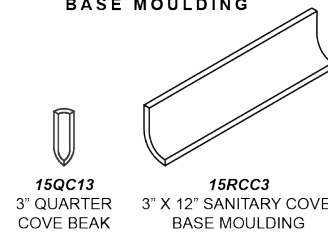

The Cosmopolitan Tile glaze series is a love letter to the modern era of architecture. Shades ranging from rich and moody to soft and pastel evokes the spirit of this design period. The gloss finish is perfect for any area of your home.



34 Gloss Julep



36 Gloss Celeste



37 Gloss Primrose



74 Gloss Concorde Blue



83 Gloss Pomegranate



84 Gloss Apricot



85 Gloss Eggplant



86 Gloss Earl Gray



87 Gloss Artichoke

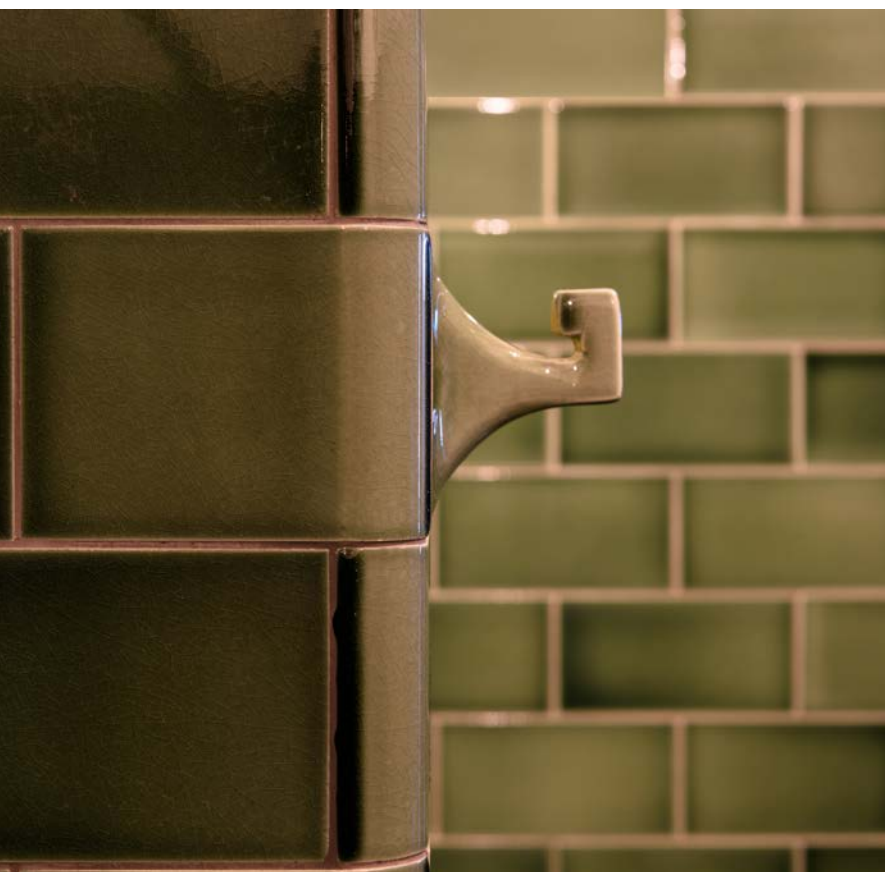

Like a fingerprint, no one tile is the same. Variation is an inherent charm of our special crackle glazes. It is what gives a tiled field and its accessories life and a unique handcrafted look typical in the early 1900s. It is common for a tiled field in our accent colors to create a smooth gradient. The unique profiles of mouldings and trim retain more glaze which shows more definition. The curved surfaces offer a softer definition while depressions and edges are accentuated with pooling glaze.

A Uniform: Glazes with no color variation between tiles



B Subtle: Satin glazes create an elegant space with colors varying slightly between tiles



C Moderate: Some color variation between tiles creates a distinctive space



D Dramatic: Eye-catching color differences between tiles offers a look that is uniquely yours



Our Inspiration

Our inspiration comes from a desire to preserve the heritage of authentic American tile. Subway tile was first found predominantly in the train stations of New York city and eventually found its way into homes and public spaces in the late 1800s through the mid-1900s. The tile originally became popular because it was considered to be clean and sanitary, and has since become a classic style around the world.



Ernest Hemingway's Boyhood Home - Oak Park
Left • 3x6 tile in Gloss White
Top Right • niche design
Bottom Right • 1x6 tile liner in Gloss Black



Heritage Tile Showroom - Oak Park
Top Left • 3x6 tile in Heather Grey
Top Right • towel bar
Bottom • 6x6 sanitary cove base moulding in Gloss Black

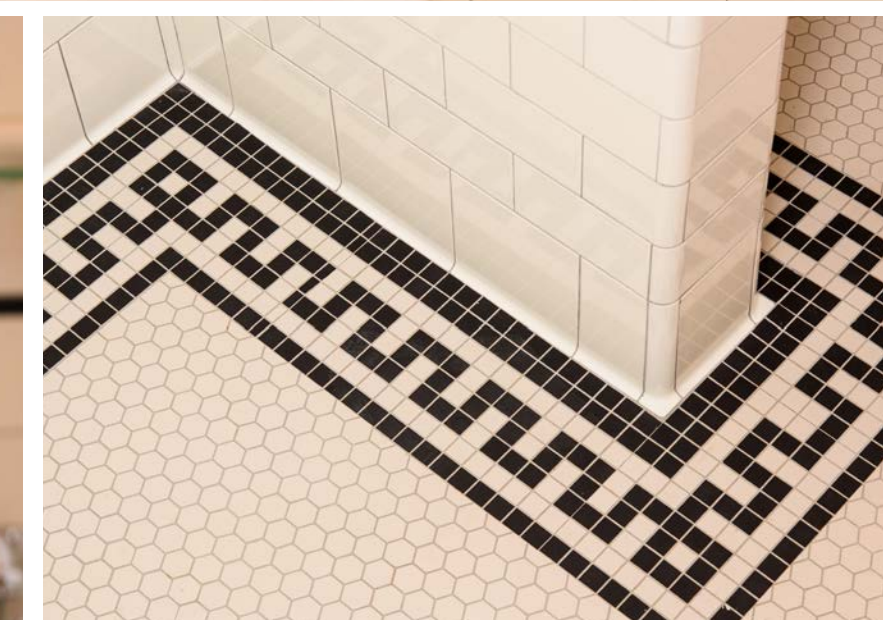

Oak Park River Forest Museum (Cicero Firehouse #2)
Top • 3x6 tile in Gloss Avalon
Bottom Right • custom floor mosaic
Bottom Left • 1x6 tile liner in Gloss Black

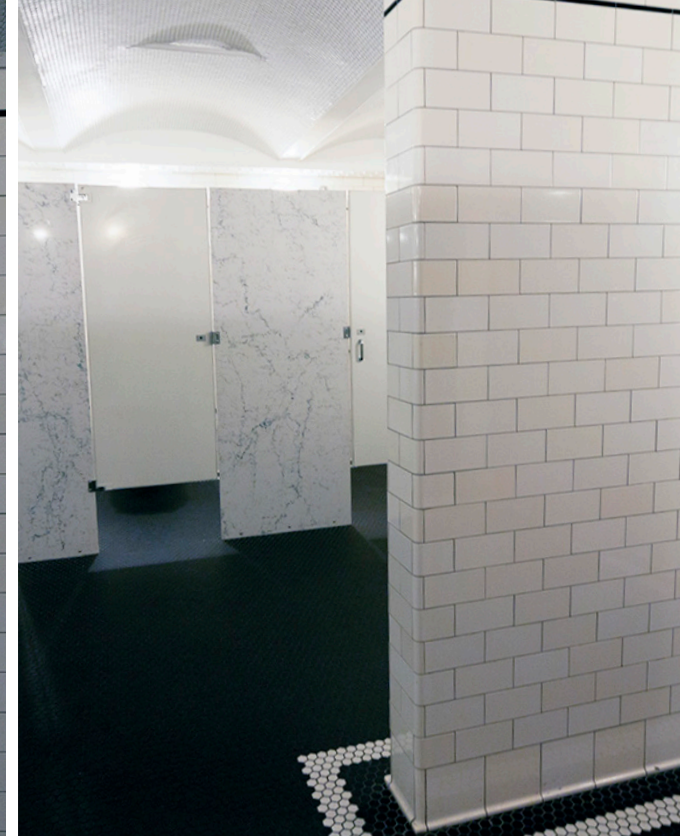

Chelsea Market - NYC
Top Left • classic mosaic floor with border
Top Right • large radius bullnose corner tiles
Bottom • 3x6 tile in Satin White

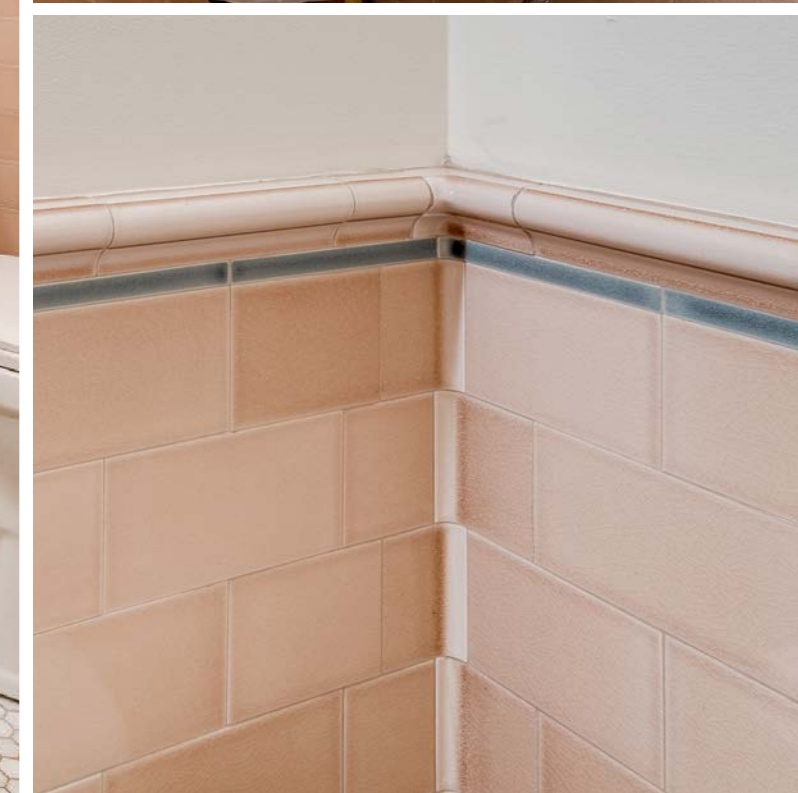

123 South Grove Avenue - Oak Park
Left • 3x6 tile in Blush
Top Right • shelf support
Bottom Right • 1.5x6 p-cap





Royal Coffee Tasting Room - Oakland
2-3/4" hex tile in Gloss Emerald Green



The Dutch - NYC
6x6 tile in Gloss Marine Blue



Restaurant Kommendören - Stockholm
Top Left • 3x6 tile in Gloss White
Bottom Left • 3x6 tile in Gloss White
Right • column surround with 1.5x6 p-cap

Our historic tile is beautifully crafted with design, tradition and functionality in mind. Whether you're looking for a classic design or want to use historically authentic tile for a more modern installation, we've got the tools to help you achieve your dream space.

HERITAGETILE.COM:



Our website provides an optimal viewing experience for architects and interior designers. Catalogs, design guides, assembly diagrams, inspiration images, and test certifications are right at your fingertips. This easy-to-access information is designed to help you evaluate, present, and select inspiring tile solutions for your projects. You can also easily order sample books and cards to review our colors and product quality first-hand.

SAMPLE PROGRAM:



No two projects are alike. We offer resources to meet the unique design challenges of your space. Our Sample Books and Cards are a hands-on way to see the quality, beauty and character of our product. Request our sample books and cards to keep in your material library for reference.

DESIGN CONSULTANTS:



Consider Heritage Tile as your partner committed to the success of your project. We sincerely care about our craft, and are eager to share our experience and design resources with you. Design Consultants are here to assist you from concept and design, to installation and maintenance. We will answer questions and keep you updated with new products, exciting projects and design inspiration. Our commitment is always to you, feel free to reach out with design questions, sample requests, or order specifications. We are ready to help.

EDUCATION AND DEVELOPMENT:



Continue your education with Heritage Tile. Our AIA/IDCEC accredited CEU programs offer something for everyone. Whether you are interested in the dynamic changes of thought and design at the turn of the century, or are curious how a 16th century Japanese aesthetic is connected to Frank Lloyd Wright, we have a course for you.

Our **Project Guide Codex** is your guide to all things Subway Ceramics and how to implement this historically accurate system of products into your project. The guide book has all the references, options and installation CADs you will need to create a new design or restore a historic space. See our Project Design Guide in the Resources & Tools tab on our website.

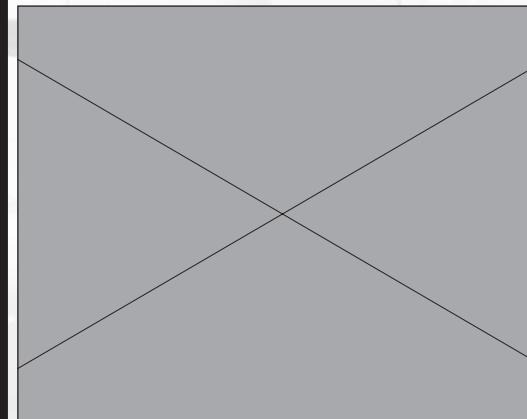

Base Cove and Inside Corner

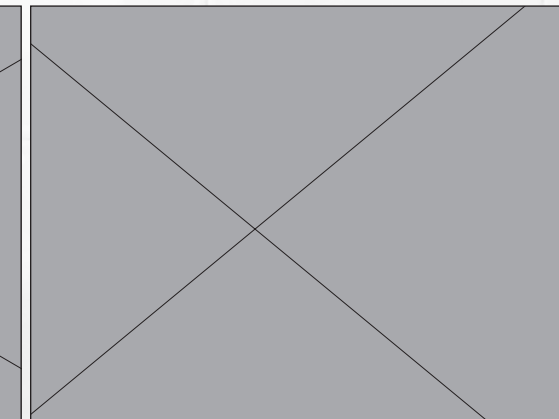

Mirror Surround and Shelf Supports

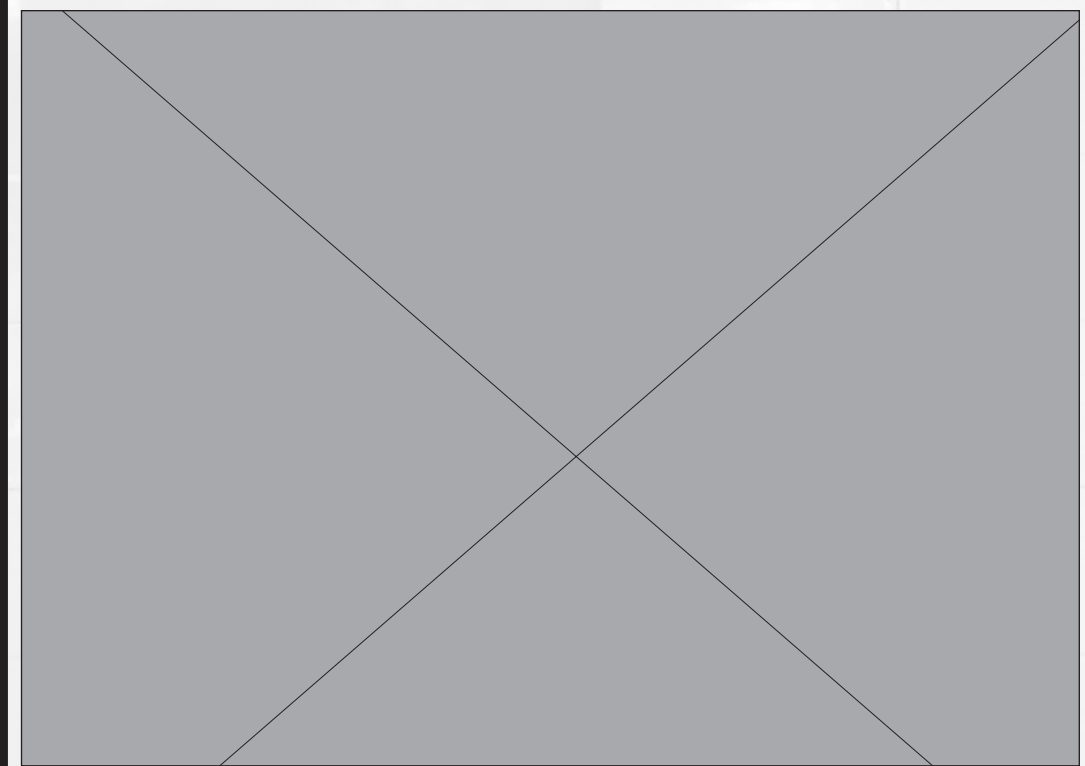



1
Prepare all surfaces to be completely flat & level to avoid irregularities. For any wet or humid areas the use of CBUs are recommended. For any other conditions, substrates made of gypsum board are appropriate.



2
Carefully begin to plan installation including starting points (base), balanced proportions, indicating special treatments, and proper joint alignment. For historically accurate use a nominal 1/32" to 1/16" spacing.



3
Cutting of tiles is done only with the use of a wet saw. To get a clean edge off cuts, we recommend consistently keeping a premium quality ceramic tile blade on hand to avoid jagged cuts.



4
Tip: Soaking the tiles in clean water will help give an installer additional time when setting tiles. This will allow the installer to adjust coursing or individual tiles as necessary and flexibility to beat-in the tiles flat.



5
Tip: Use a rubber mallet and wood beating block as cushion to gently beat the tile as it is set to ensure a flat finished surface. Pre-preparation of the surface coupled with this technique will eliminate unwanted lippage.



6
Apply mortar using a 1/4" trowel or larger. For enhanced adhesion, backbutter tiles along with the wall or floor surfaces. Pre-mixed tile adhesives products are not recommended in any circumstances.



7
Note: Radius Trim or any other specialized trim may require additional planning or alternate surface preparation. It is recommended these considerations are well planned prior to tiling.



8
After the tile is set properly, carefully apply a premium unsanded grout. After the grout has fully cured, apply penetrating grout sealer. Note: Crackle glazes need to be sealed prior to grouting as well as after grouting.

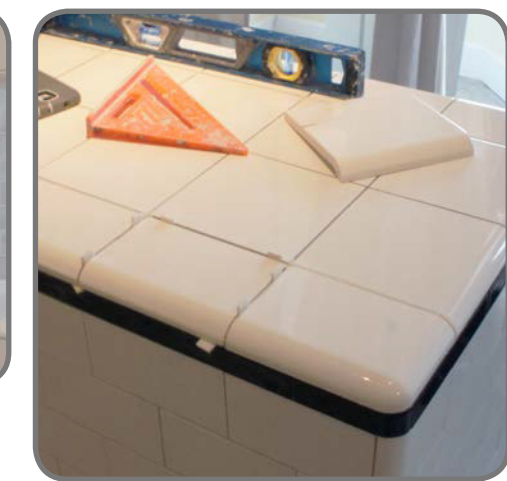

Please Contact Us for Additional Information.

Product Information

Subway Ceramics includes classic moldings, trim pieces, and ceramic accessories which give visual appeal that help retain a home's value. No matter which option you choose, your tile retains historically accurate features, including flat surfaces with pencil thin grout lines. Thin grout lines aren't just aesthetically pleasing, they are also easy to clean, making your home surfaces immaculate with minimal effort. Subway Ceramics is a part of a comprehensive tile system that provides luxurious surfaces, sleek radius curves, and intricate details that Heritage Tile takes pride in producing daily.



Liners

Field Tiles



22FT00 2" x 2"
Field Tile

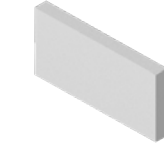

24FT00 2-1/8" x 4-1/4"
Field Tile



24FT01 2" x 4"
Field Tile

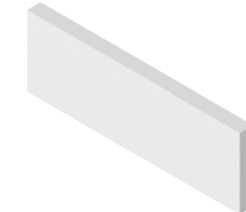

26FT00 2" x 6"
Field Tile



33FT00 3" x 3"
Field Tile



36FT00 3" x 6"
Field Tile



3CFT00 3" x 12"
Field Tile



44FT00 4-1/4" x 4-1/4"
Field Tile

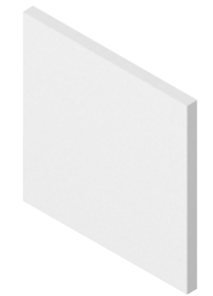

66FT00 6" x 6"
Field Tile



69FT00 6" x 9"
Field Tile

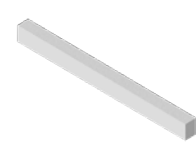

06LN00 1/2" X 6"
Flat Accent Liner

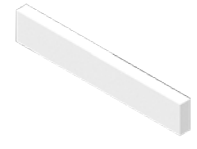

16LN00 1" x 6"
Flat Accent Liner

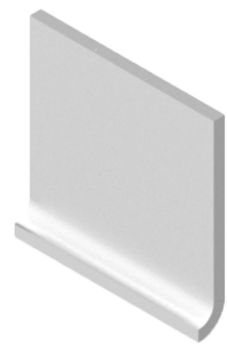

66CB00 6" x 6" Sanitary Cove
Base moulding



66CB2L 6" x 6" Sanitary
Cove Base end stop - left



66CB2R 6" x 6" Sanitary
Cove Base end stop - Right



06CB01 6" Sanitary Cove
Base - outside corner



06SC01 6" Shoulder Cove
Base - outside corner



06SC02 6" Shoulder Cove
Base - inside corner

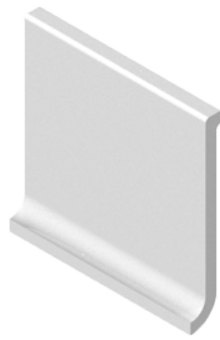

66SC00 6" x 6" Shoulder Cove
Base moulding



66SC2L 6" x 6" Shoulder Cove
base endstop - left



66SC2R 6" x 6" Shoulder Cove
base endstop - right



22EC01 2" x 2" Ellis Cove
Base - outside corner [for use with
radius bullnose or quarter round trims]



22EC02 2" x 2" Ellis Cove
Base - inside corner [for use with
radius cove or quarter cove trims]



22EC03 2" x 2" Ellis Cove
Base - inside corner [for use with
non-radius inside corner treatment]



66RB00 6" x 6" Roman Base
moulding



06RB01 6" Roman Cove Base
-Outside Corner



22EC04 2" x 2" Ellis Cove
Base - inside corner [for use with
Ellis Cove as vertical cove trim]



26EC00 2" x 6" Ellis Cove
Base moulding [1-3/8" total piece pro-
file width, protrudes 1" when tiled -in]



06LN01 1/2" x 6"
Flat Liner - surface bullnose



16LN01 1" x 6"
Flat Liner - surface bullnose



24SB20 2" x 4"
Surface Bullnose - short



33SB03 3" x 3"
Surface Bullnose



33IB33 3" x 3"
Inside Corner Bullnose



33DB33 3" x 3"
Down Corner Bullnose



24SB40 2" x 4"
Surface Bullnose - long



24SB02 2-1/8" x 4-1/4"
Surface Bullnose - short



24SB04 2-1/8" x 4-1/4"
Surface Bullnose - long



36DB36 3" x 6"
Bullnose Down Corner - left



36DB63 3" x 6"
Bullnose Down Corner - right

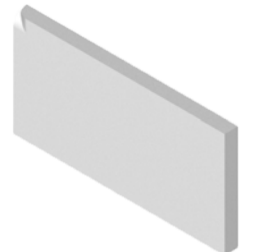

36IB36 3" x 6"
Inside Corner Bullnose - left



26DB26 2" x 6"
Bullnose Down Corner - left



26DB62 2" x 6"
Bullnose Down Corner - right



26SB02 2" x 6"
Surface Bullnose - short



36IB63 3" x 6"
Inside Corner Bullnose - right



36SB03 3" x 6"
Surface Bullnose - short

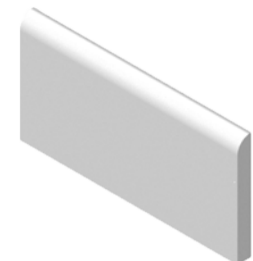

36SB06 3" x 6"
Surface Bullnose - long



26SB06 2" x 6"
Surface Bullnose - long

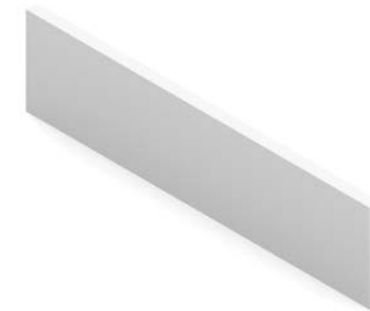

3CSB03 3" x 12"
Surface Bullnose - short

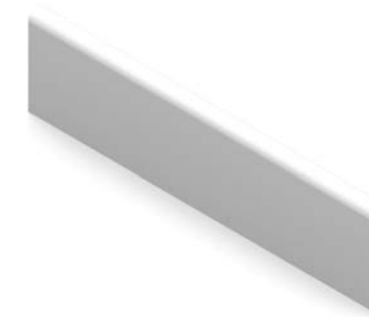

3CSB0C 3" x 12"
Surface Bullnose - long

Surface Trims



3CDB3C 3" x 12"
Down Corner - left

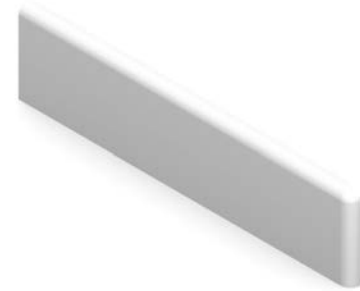

3CDBC3 3" x 12"
Down Corner - right



44DB44 4-1/4" x 4-1/4"
Down Corner Bullnose

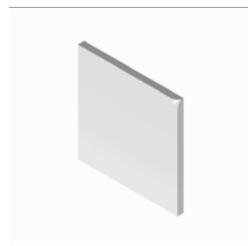

44IB44 4-1/4" x 4-1/4"
Up Corner Bullnose



44SB04 4-1/4" x 4-1/4"
Surface Bullnose



66DB66 6" x 6"
Down Corner Bullnose

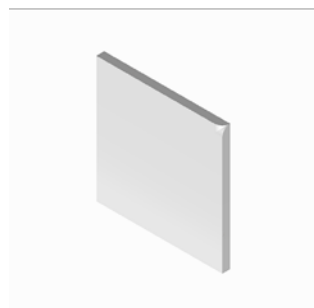

66IB66 6" x 6"
Bullnose Inside Corner



66SB06 6" x 6"
Surface Bullnose



69DB69 6" x 9"
Down Corner Bullnose - left



69DB96 6" x 9"
Down Corner Bullnose - right



69SB06 6" x 9"
Bullnose - short



69SB09 6" x 9"
Bullnose - long

Radius Trims



06RB00 1/2" x 6"
Radius Bullnose - short trim



06RC00 1/2" x 6"
Radius Cove - short trim



16RB01 1" x 6"
Radius Bullnose - short trim



16RC01 1" x 6"
Radius Cove - short trim



22RD22 2" x 2"
Radius Down Corner

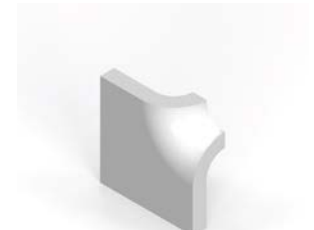

22RU22 2-1/2" x 2-1/2"
Full Radius Up Corner

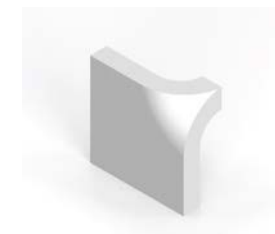

22SU22 2" x 2"
Square Radius Up Corner



23RB02 2" x 3-3/4"
Radius Bullnose



23RC02 2" x 3-3/4"
Radius Cove



26RB02 2" x 6"
Radius Bullnose



26RC02 2" x 6"
Radius Cove



33RB03 3" x 3-3/4"
Radius Bullnose



44RB04 4-1/4" x 4-1/4"
Radius Bullnose



44RC04 4-1/4" x 4-1/4"
Radius Cove



44RC44 4-1/4" x 4-1/4"
Radius Cove Corner



33RC03 3" x 3-3/4"
Radius Cove



36RB03 3" x 6"
Radius Bullnose - short



36RC03 3" x 6"
Radius Cove - short



44RD44 4-1/4" x 4-1/4"
Radius Down Corner - right



44RU44 4-1/4" x 4-1/4"
Radius Up Corner



44SU44 4-1/4" x 4-1/4"
Square Up Corner



36RB06 3" x 6"
Radius Bullnose - long



36RC06 3" x 6"
Radius Cove - long



36RC36 3" x 6"
Radius Cove Down Corner - left



66RB06 6" X 6"
Radius Bullnose



66RC06 6" x 6"
Radius Cove



66RC66 6" x 6"
Radius Cove Corner



36RC63 3" x 6"
Radius Cove Down Corner - right



36RD36 3" x 6"
Radius Down Corner - left



36RD63 3" x 6"
Radius Down Corner - right



66RD66 6" x 6"
Radius Down Corner

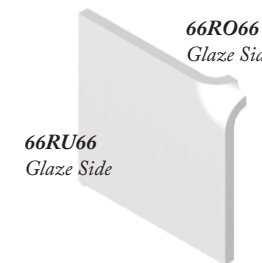

66RU66 6" x 6"
Radius Up Corner

66RO66
Glaze Side

66RO66 6" x 6"
Radius Out Corner



66SU66 6" x 6"
Square Up Corner

66SO66
Glaze Side

66SO66 6" x 6"
Square Out Corner



00QC01
Quarter Cove - 3-way corner

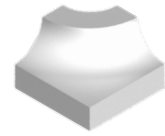

00QC02
Quarter Cove - outside corner



00QR01
Quarter Round - 3-way corner



06QR00
6" Quarter Round



06QR01
6" Quarter Round Beak



06QR02
6" Bullnose Quarter Round

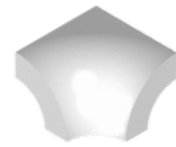

00QR02
Quarter Round - inside corner



02QR01
2" Quarter Round Beak



06MC02 6" Quarter Cove /
Mud Cap inside corner



06QC00
6" Quarter Cove



06QC01 6" Quarter Cove Beak/
Sanitary Cove Base - inside corner



06QC02 6" Bullnose Quarter
Cove - inside corner

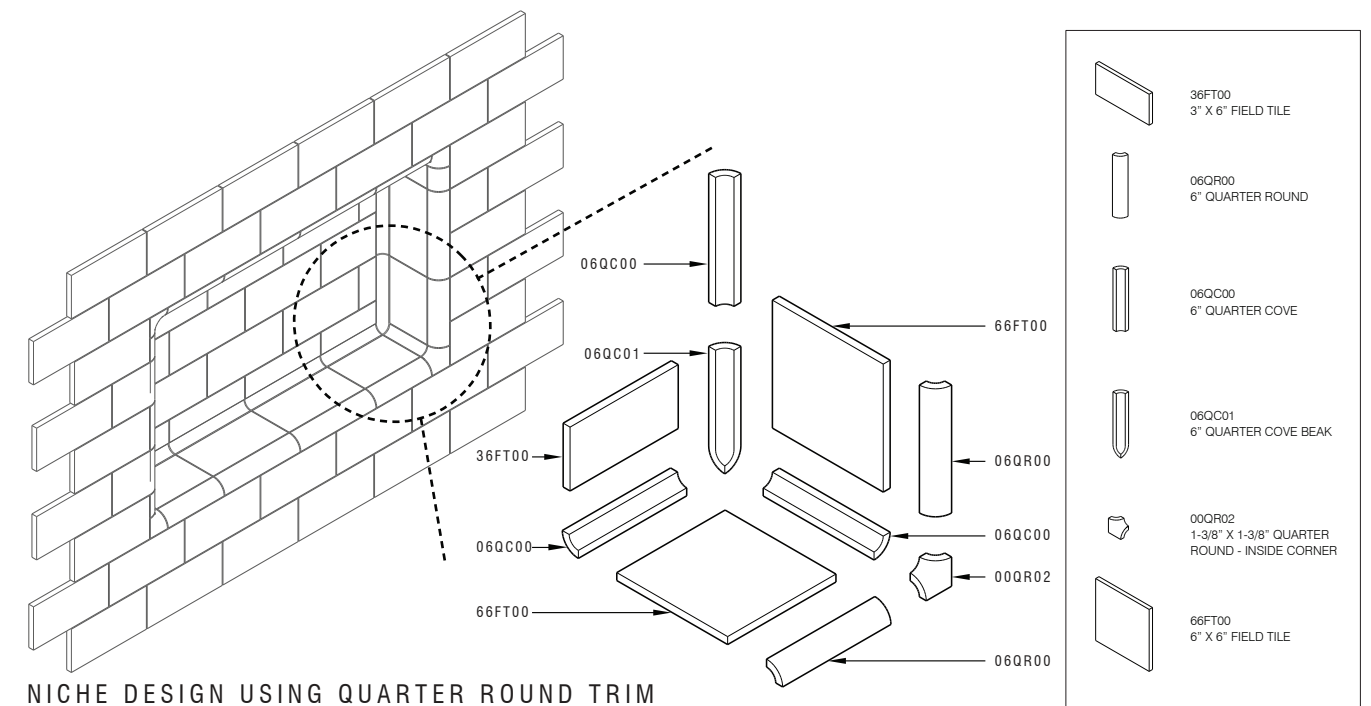

Product Code	Description
36FT00	3" X 6" FIELD TILE
06QR00	6" QUARTER ROUND
06QC00	6" QUARTER COVE
06QC01	6" QUARTER COVE BEAK
00QR02	1-3/8" X 1-3/8" QUARTER ROUND - INSIDE CORNER
66FT00	6" X 6" FIELD TILE

SCHEDULE OF TILES



02MC02 2" Mud Cap -
inside corner

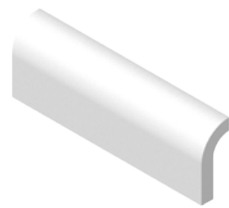

26MC00 2" x 6" Mud Cap
Moulding

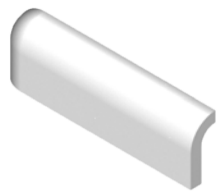

26RD26 2" x 6" Left Radius
Down



26RD62 2" x 6" Right Radius
Down

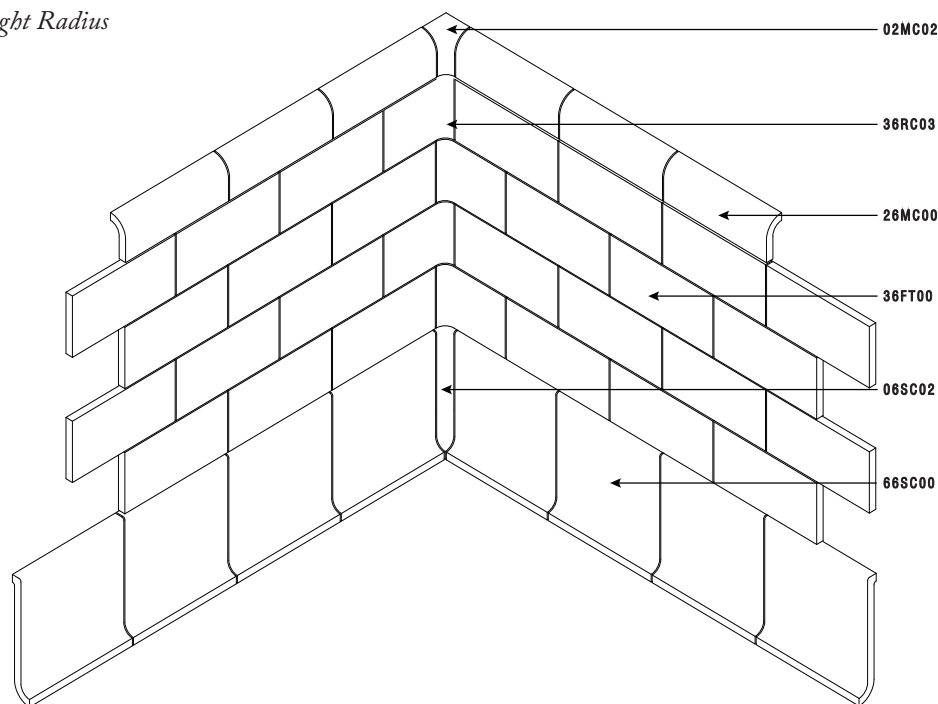

IN-CORNER WITH MUD CAP & SHOULDER COVE BASE

	36FT00 3" X 6" FIELD TILE
	36RC03 3" X 6" RADIUS BULLNOSE
	26MC00 2" X 6" MUD CAP
	02MC02 2" MUD CAP INSIDE CORNER
	66SC00 6" X 6" SHOULDER COVE BASE MOULDING
	66SC02 6" SHOULDER COVE BASE INSIDESIDE CORNER

SCHEDULE OF TILES
SOME TILES MAY HAVE BEEN CUT TO FIT*

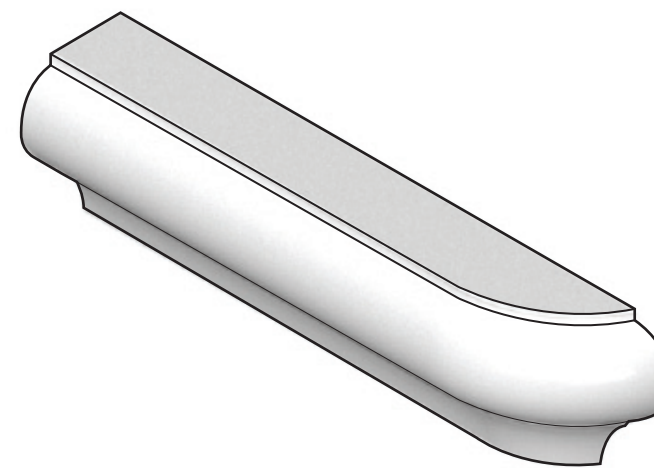
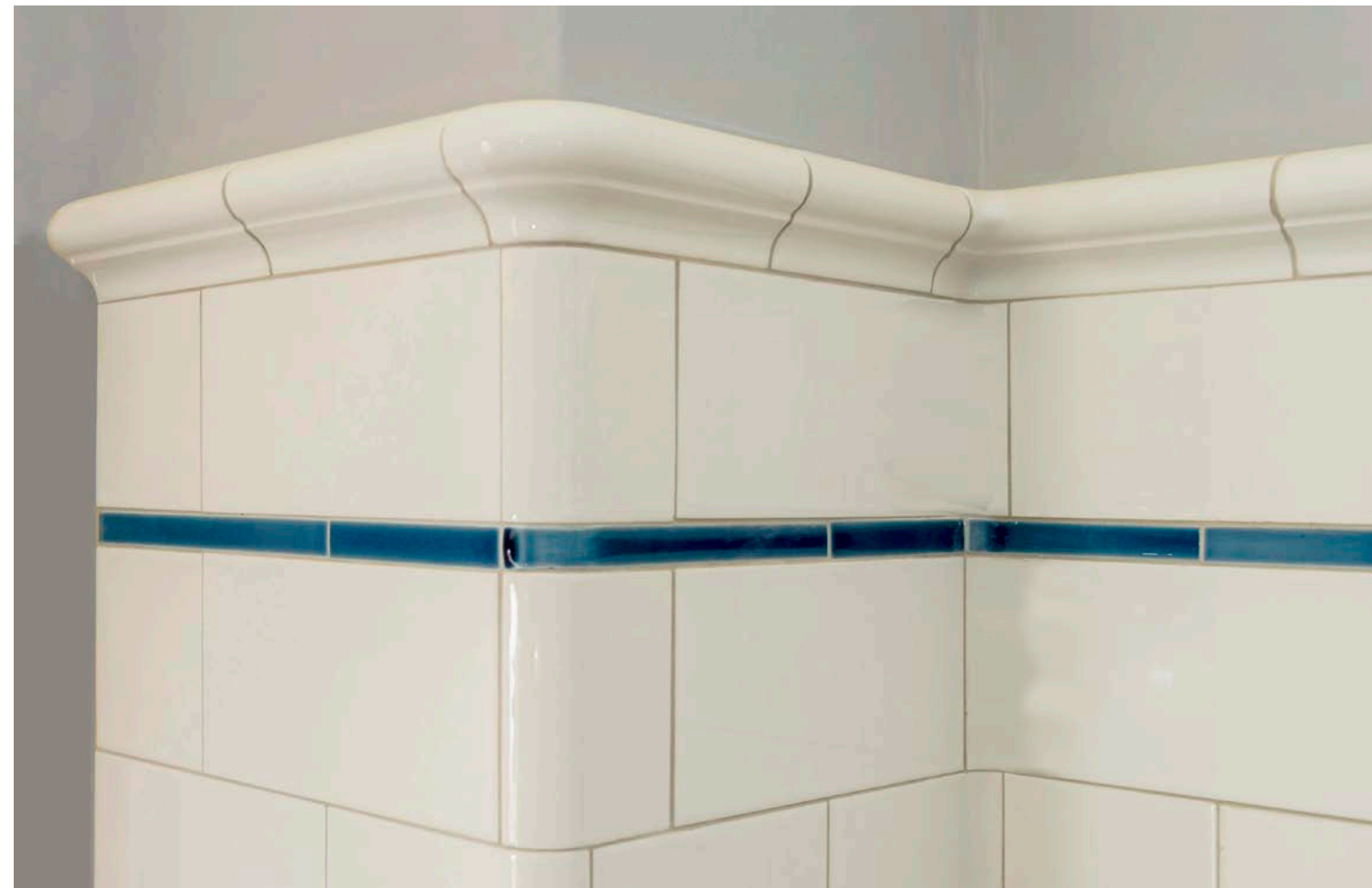

STANDARD P-CAP

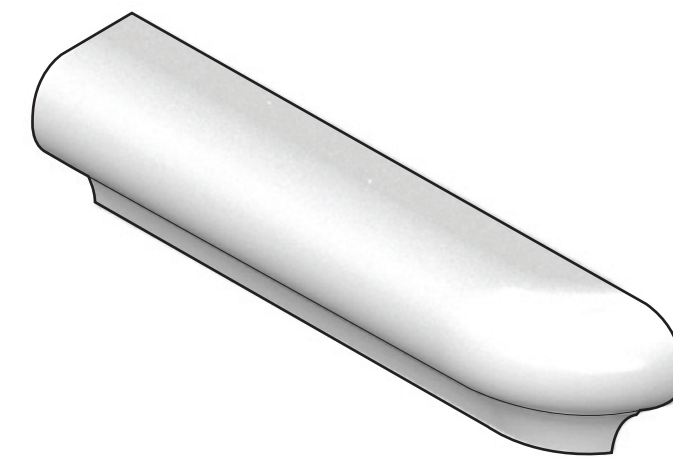

SMOOTH P-CAP

vs.

(All P-Cap styles are available in both Standard and Smooth)



11PC07 2" x 2"
P-cap Moulding - frame outside
corner
11PS07 (smooth)

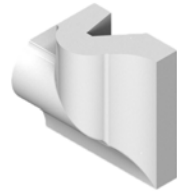

11PC08 2" x 2" P-cap Frame
Corner - inside [for transitioning
wainscot vertically]
11PS08 (smooth)



16PC00 1-1/2" X 6" P-cap
Moulding
16PS00 (smooth)



16PC4L 1-1/2" x 6" P-cap
Bullnose Stop - left [for use with
surface trim only]
16PS4L (smooth)



16PC4R 1-1/2" x 6" P-cap
Bullnose Stop - right [for use
with surface trim only]
16PS4R (smooth)



16PC6L 1-1/2" X 6" P-cap
Radius Outside Corner Return
- left
16PS6L (smooth)



16PC1L 1-1/2" x 6" P-cap
Conventional Outside Corner
Return - left
16PS1L (smooth)



16PC1R 1-1/2" x 6" P-cap
Conventional Outside Corner
Return - right
16PS1R (smooth)



16PC2L 1-1/2" x 6" P-cap
End Stop - left
16PS2L (smooth)



16PC6R 1-1/2" x 6" P-cap
Radius Outside Corner Return
- right
16PS6R (smooth)



16PC2R 1-1/2" x 6" P-cap
End stop - right [flat edge not
glazed]
16PS2R (smooth)



16PC3L 1-1/2" x 6" P-cap
Inside Corner- left [for use with
quarter cove or radius cove trims]
16PS3L (smooth)

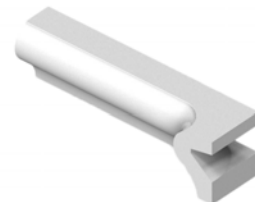

16PC3R 1-1/2" x 6" P-cap In-
side Corner - right [for use with
quarter cove or radius cove trims]
16PS3R (smooth)



11PE07 1-1/2" x 1-1/2" extended P-cap molding - Outside frame corner

11PT07 (smooth)



11PE08 1-1/2" x 1-1/2" extended P-cap molding - Inside frame corner

11PT08 (smooth)

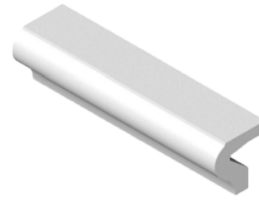

16PE00 1-1/2" X 6" Extended P-cap molding

16PT00 (smooth)



16PE4L 1-1/2" x 6" Extended P-cap bullnose end stop - left

16PT4L (smooth)

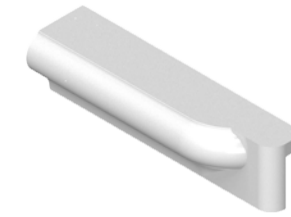

16PE4R 1-1/2" x 6" Extended P-cap bullnose end stop - Right

16PT4R (smooth)

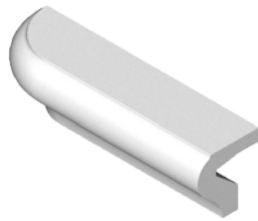

16PE1L 1-1/2" x 6" Extended P-cap conventional outside corner return - left [for use with radius bullnose or quarter round trims]

16PT1L (smooth)

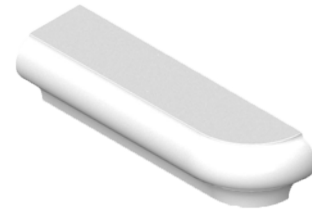

16PE1R 1-1/2" x 6" Extended P-cap conventional outside corner return - right [for use with radius bullnose or quarter round trims]

16PT1R (smooth)



16PE2L 1-1/2" x 6" Extended P-cap end stop - left

16PT2L (smooth)

OUT-CORNER WITH P-CAP/ SHOULDER COVE BASE

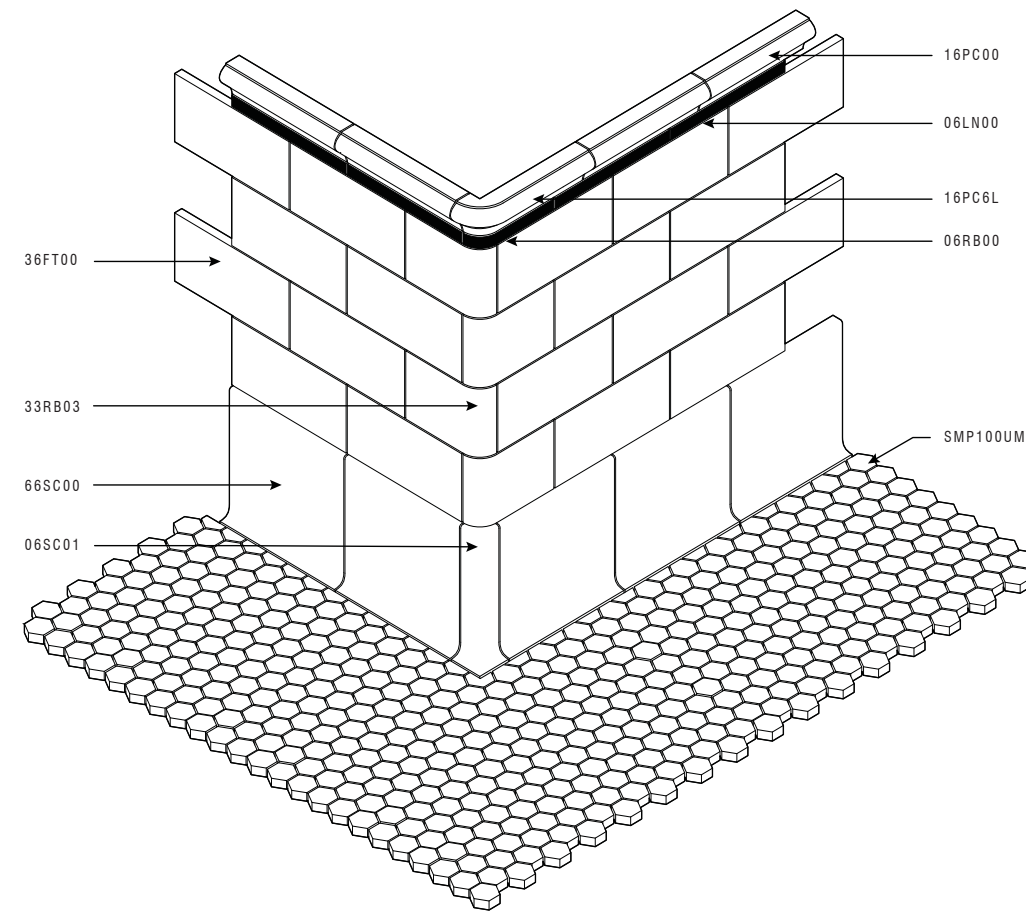

	36FT00 3" X 6" FIELD TILE
	33RB03 3" X 3" RADIUS BULLNOSE
	16PC00 3" X 6" VICTORIA CAP
	16PC6L/R 1-1/2" X 6" P-CAP RADIUS OUTSIDE CORNER RETURN
	06LN00 1/2" X 6" ACCENT LINER
	06RB00 1/2" X 6" RADIUS BULLNOSE
	06SC01 6" SHOULDER COVE BASE OUTSIDE CORNER
	66SC00 6" X 6" SHOULDER COVE BASE Moulding
	SMP100UM 1" HEX MOSAIC (ARCTIC)

SOME TILE MAY HAVE BEEN CUT TO FIT
SCHEDULE OF TILES

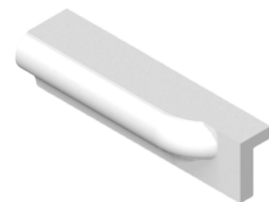

16PE2R 1-1/2" x 6" Extended Field Tile P-cap end stop - right

16PT2R (smooth)

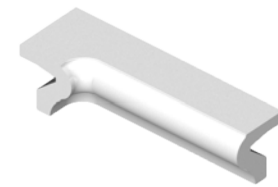

16PE3L 1-1/2" x 6" Extended P-cap inside corner - left [for use with quarter cove or radius cove trims]

16PT3L (smooth)

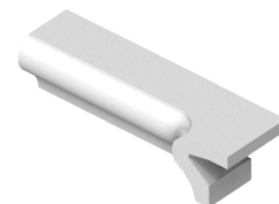

16PE3R 1-1/2" x 6" Extended P-cap inside corner - right [for use with quarter cove or radius cove trims]

16PT3R (smooth)



22BX07 2" x 2" Box Cap
Frame Corner - outside



22BX08 2" x 2" Box Cap -
inside corner

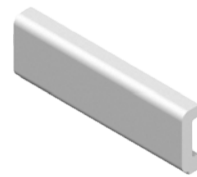

26BX00 2" X 6" Box Cap
Moulding

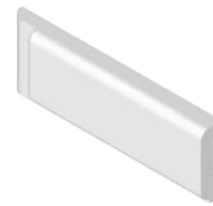

26BX4L 2" x 6" Box Cap
Bullnose Stop - left



26BX4R 2" x 6" Box Cap
Bullnose Stop - right



26BX6R 2" x 6" Box Cap
Radius Outside Corner
Return - right



26BX1L 2" x 6" Box Cap
Conventional Outside Corner
Return - left



26BX1R 2" x 6" Box Cap
Conventional Outside Corner
Return - right



26BX2L 2" x 6" Box Cap End
Stop - left



26BX6L 2" X 6" Box Cap
Radius Outside Corner
Return - left



26BX2R 2" x 6" Box Cap End
Stop - right

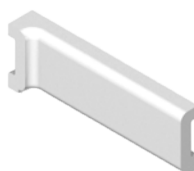

26BX3L 2" x 6" Box Cap Inside
Corner - left



26BX3R 2" x 6" Box Cap Inside
Corner - right

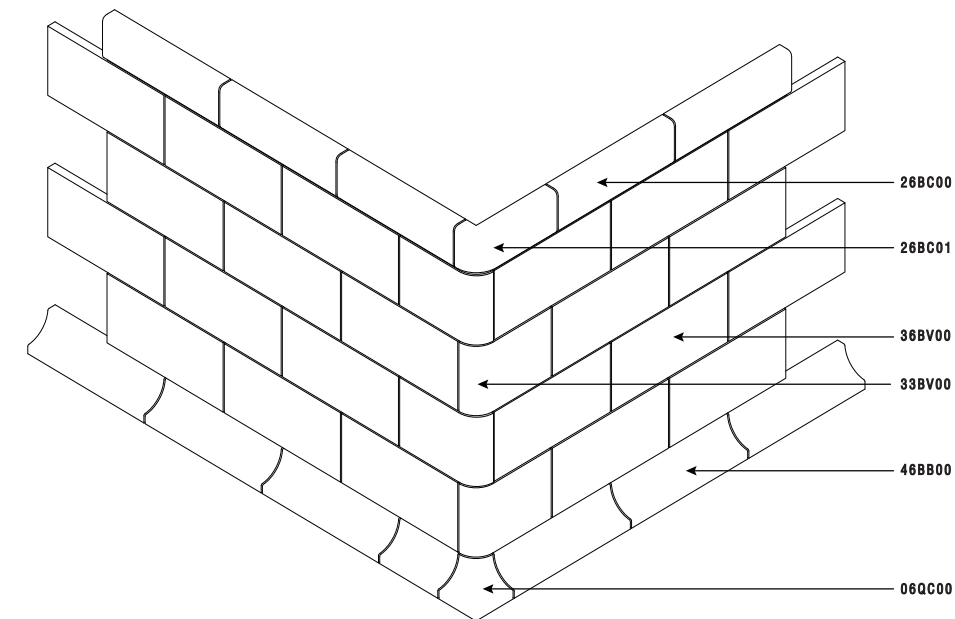

OUT-CORNER WITH BOX CAP & ELLIS COVE BASE

	36FT00 3" X 6" FIELD TILE
	33RB03 3" X 3" RADIUS BULLNOSE
	26BX00 2" X 6" BOX CAP MOULDING
	26BX6L 2" X 6" BOX CAP RADIUS OUTSIDE CORNER RETURN
	26EC00 2" X 6" ELLIS COVE BASE MOULDING
	22EC01 2" X 2" ELLIS COVE BASE OUTSIDE CORNER

SCHEDULE OF TILES



33VC06 3" x 3" Victoria Cap
Frame Corner - outside



33VC07 3" x 3" Victoria Cap
Frame Corner - inside



36VC00 3" X 6" Victoria Cap

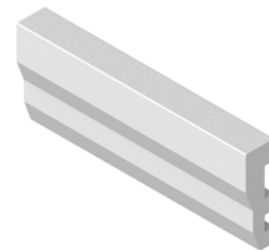

26BC00 2-3/8" X 6" Beveled
Cap Moulding



26BC01 2-3/8" Beveled Cap
Moulding Outside Corner



26BC02 2-3/8" Beveled Cap
moulding - Inside corner



36VC01 3" Victoria Cap
Outside Corner



36VC03 3" Victoria Cap Inside
Corner



36VC04 3" Victoria Cap Inside
Corner - Squared

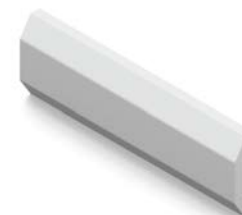

26BL00 2" x 6" Bevel liner



26BL01 2" x 6" Bevel Liner -
bevel outside corner trim/ end stop



33BV00 3" x 3" Bevel Field
(sold in 3.5 sq ft increments)



36VC2L 3" Victoria Cap
End Stop - left



36VC2R 3" Victoria Cap
End Stop - right



36BV00 3" x 6" Bevel Field
(sold in 3.5 sq ft increments)



03BC00
3" Bevel Inside Corner Cove



03BR00
3" Bevel Outside Corner Round



46BB00 4-3/8" x 6" Beveled Base Moulding



46BB01 4-3/8" x 6" Bevel Base Moulding Outside Corner (for use with radius bullnose or quarter round trims)



46BB02 4-3/8" x 6" Bevel Base moulding Inside Corner (for use with radius cove or quarter cove trims)



33HD00 2-3/4" x 2-3/4" Hex Dome Field Tile



33HX00 2-3/4" x 2-3/4" Hex Flat Field Tile



33HX4P 2-3/4" x 2-3/4" Hex Flat Field Tile - 4-point trim

Specialty Field Tile



33HX5P 2-3/4" x 2-3/4" Hex Flat Field Tile - 5-point trim



44RT01 Sculptured Tile - Diamond Pattern

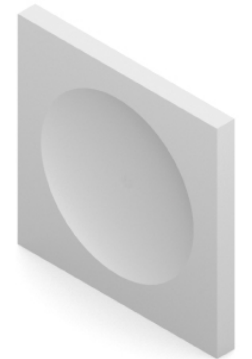

44RT02 Sculptured Tile - Sphere Pattern



36BW00 3" x 6" Basketweave Field / Border



66BW00 6" x 6" Basketweave Field / Border

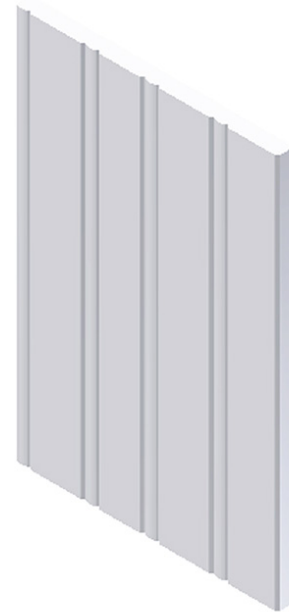

69BB00 6" x 9" Beadboard Tile



44RT03 Sculptured Tile - Star Pattern



3CFTC2 3" x 12" Corrugated Texture Field Tile

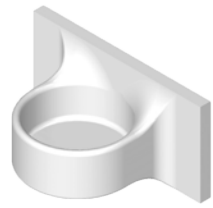

36CH00 3" x 6" Tile-in Cup Holder

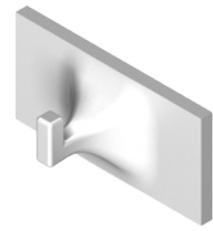

36RH00 3" x 6" Tile-in Robe Hook (protrudes 2-1/8" when tiled-in)



36SD00 3" x 6" Recessed Soap Dish (2-5/8" interior depth)



1C82SX 3.5" x 5" Single Standard Switch Cover Plate



1C83OX 3.5" x 5" Single Duplex Outlet Cover Plate



1C84RX 3.5" x 5" Single GFI/Rocker Switch Cover Plate



36SS00 3" x 6" Tile-in Shelf Support (buy two for pair)

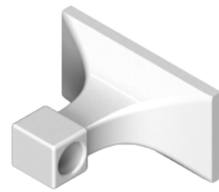

36TB00 3" x 6" Tile-in Towel Bar End (buy two for a pair)



44CH00 4-1/4" x 4-1/4" Tile-in Cup Holder



2C85SS 5" x 5" Double Standard Switch Cover Plate



2C86SO 5" x 5" Double Switch/Duplex Outlet Cover Plate

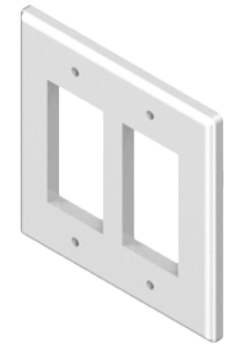

2C89RR 5" x 5" Double GFI/Rocker Switch Cover Plate



44RH00 4-1/4" x 4-1/4" Tile-in Robe Hook (protrudes 4-3/8" when tiled-in)



44SD00 4-1/4" x 4-1/4" Soap Dish



44SS00 4-1/4" x 4-1/4" Shelf Support (buy two for a pair)



2C94SR 5" x 5" Double Switch & GFI/Rocker Switch Cover Plate

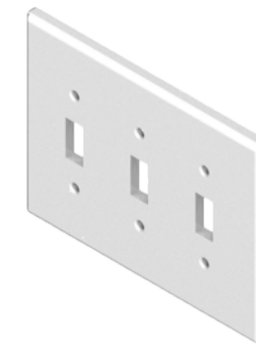

3C92SS 6-7/8" x 5" Triple Switch Cover Plate

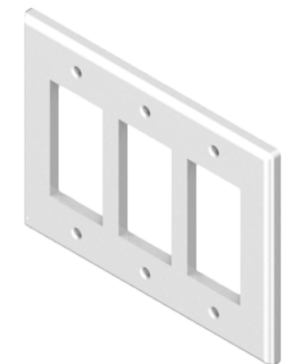

3C93RR 6-7/8" x 5" Triple GFI/Rocker Switch Cover Plate



44TB00 4-1/4" x 4-1/4" Tile-in Towel Bar End (buy two for a pair)



66PH00 6" x 6" Recessed Paper Holder



66SD00 6" x 6" Recessed Soap Dish (3" interior depth)



15QC01
Series 15 - Quarter Cove Inside
Corner - 3/4"-radius



15QC03
Series 15 - Quarter Cove Inside
Corner - non-radius



15QC04
Series 15 - Quarter Cove Inside
Corner - 3 way

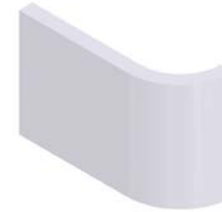

15RB33
Series 15 - 3" x 4-1/2"
Radius Bullnose

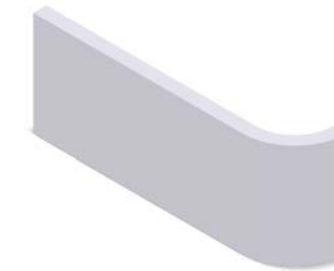

15RB63
Series 15 - 3" x 7-1/2"
Radius Bullnose



15RC33
Series 15 - 3" x 4-1/2"
Radius Cove



15QR01
Series 15 - Quarter Round Outside Corner



15QC02
Series 15 - Quarter Cove Inside Corner



15QR02
Series 15 - Quarter Round Outside Corner

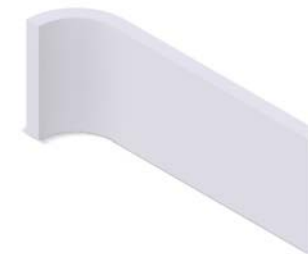

15RC63
Series 15 - 3" x 7-1/2"
Radius Cove



15PCIC
Series 15 - P-cap Inside Corner



15PCOC
Series 15 - P-cap Outside Corner



15QC13
Series 15 - 3" Quarter Cove Beak Inside
Corner - 3 way



15QR13
Series 15 - 3" Quarter Round
Beak Outside Corner - 3 way



15QC23
Series 15 - 3" Corner Round Inside
Corner



15BXIC
Series 15 - Box-cap Inside Corner



15BXOC
Series 15 - Box-cap Outside Corner



15QR23
Series 15 - 3" Corner Round
Outside Corner



15QC60
Series 15 - 6" Quarter Cove



15QR60
Series 15 - 6" Quarter Round

Series 15 Large Radius Mouldings



15QC00
Series 15 - 1.5" x 6" Ellis Cove



15RC36
Series 15 - 3" x 6" Radius Cove



15RC3C
Series 15 - 3" x 12" Radius Cove



15QR00
Series 15 - 1.5" x 6" Mud Cap



15RB36
Series 15 - 3" x 6" Radius Bullnose



15RB3C
Series 15 - 3" x 12" Radius Bullnose



15SU13
Series 15 - 1-3/8" x 3" Radius
Down Corner - right



15SU31
Series 15 - 1-3/8" x 3" Radius
Down Corner - left





The Stand - Historic Community Center



Subway Mosaics

This is a tailored service to provide you with a custom mosaic. We can create almost any design, whether it be replicating an original mosaic from a photograph, a historic catalog or even your own creation, the possibilities are limitless. A great source of inspiration for historic mosaic patterns is the Tile Heritage Foundation. They have collected many historic catalogs that demonstrate the boundless creativity of 19th century tilemakers.

We work with you through every step to create your stunning mosaic floor

1 Define your Design

What inspires you? What patterns do you love? What colors inspire or compliment your space?



2 Send us your Information

Send us any images or information about your design inspiration. If you have any floor plans, we'd love to see those too!

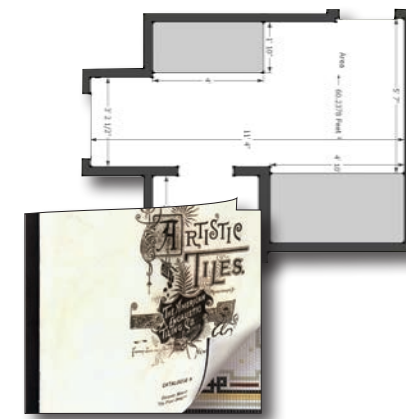

3 Work with our Designers

Please send all information to sales@heritagetile.com

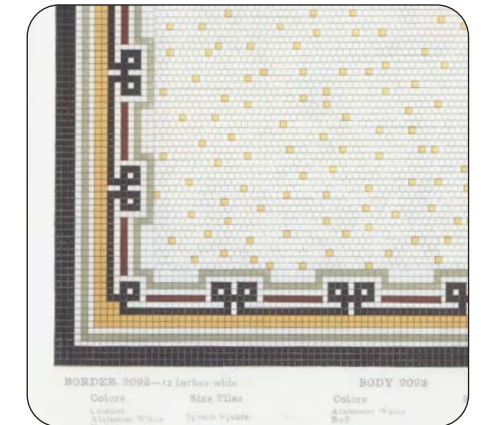

4 Order your Tile

Our designers will interpret your information and provide shop drawings of your design. This may include refining to make sure that our drawings reflect your vision.

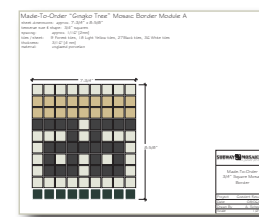

Your floor will be broken down into modules that can be repeated across your floor. Your design package will include a drawing for each module.

5 Anticipate Your Delivery

Work with your tile installer to calculate how much of each module you require for your floor. We always recommend that you order a few extra sheets to cover any unforeseen issues that may come up.



6 Install your Tile

Because your floor will be assembled like a jigsaw puzzle, we highly recommend that your tile installer assembles the design before starting installation process.



Made-to-order pricing will vary depending on shape, size and complexity of pattern. To request a quote e-mail: info@heritagetile.com

Durable, versatile and affordable mosaics have been used for more than 100 years in American architecture. Creating historically inspired mosaic patterns is still possible with Subway Mosaics. The vintage floors of pre-war homes and buildings can be re-created today. Choose from our catalog of historic classic fields and popular patterns or make your own design. With 24 colors, 4 shapes and 6 sizes, the possibilities are almost unlimited.

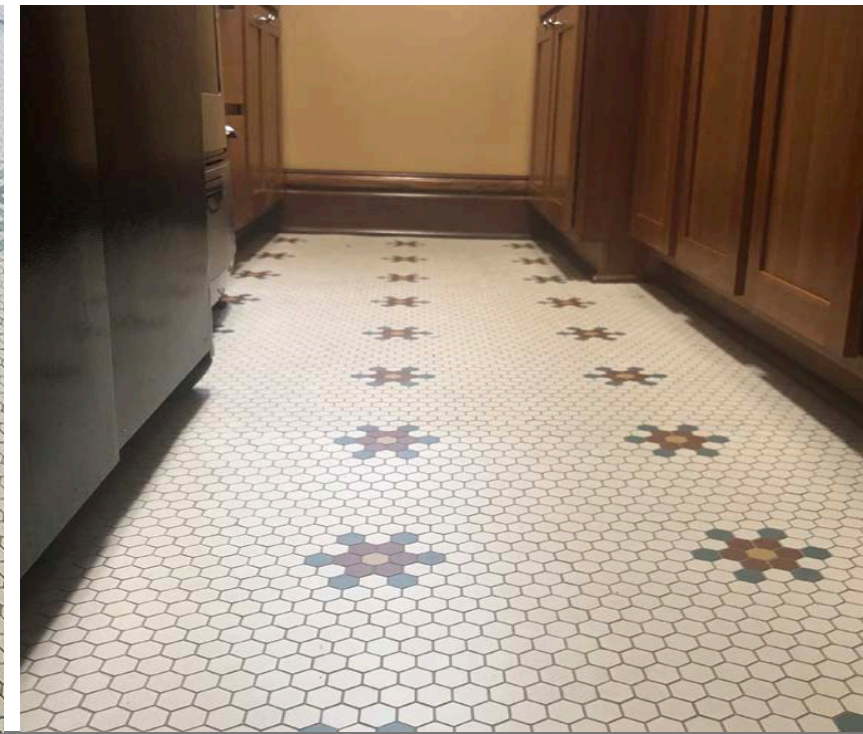

Designer Series - Custom Patterns

Step 1 - Shape

Selection of six traditional shapes.

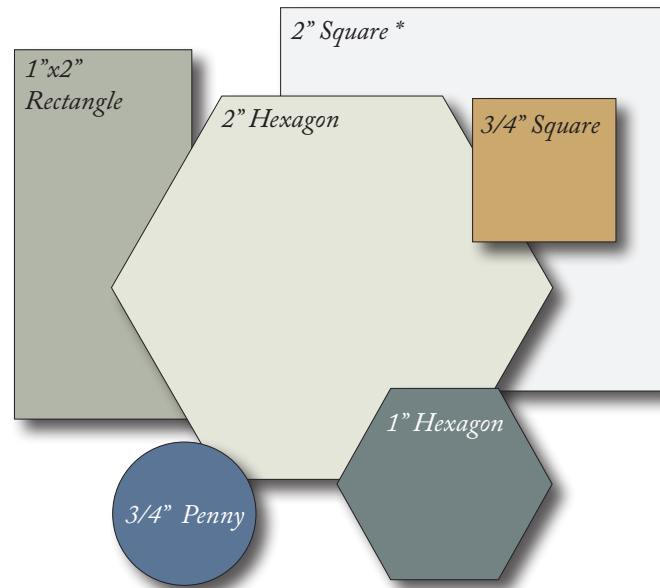

Step 2 - Color Palette

Historically authentic through-body colors in unglazed porcelain.

WH White approx. RGB 216/207/190	CM Cream approx. RGB 205/190/165	LR Light Gray approx. RGB 187/180/167	LI Linen approx. RGB 173/152/130
RS Rose approx. RGB 195/160/137	OD Orchid approx. RGB 163/153/152	DK Dark Gray approx. RGB 127/126/110	BK Black approx. RGB 78/79/77
LY Light Yellow approx. RGB 202/180/138	LN Lemon approx. RGB 211/195/152	PH Peach approx. RGB 202/171/126	GD Gold approx. RGB 188/151/98
LG Light Green approx. RGB 163/175/152	CN Celadon approx. RGB 140/155/142	GN Green approx. RGB 116/139/129	XX Olive approx. RGB 104/116/76
TQ Turquoise approx. RGB 136/150/155	YY Slate approx. RGB 118/122/129	LB Light Blue approx. RGB 119/143/158	DM Denim approx. RGB 90/121/143
SN Salmon approx. RGB 174/137/120	CL Carmel approx. RGB 159/119/81	RD Red approx. RGB 123/79/67	CH Chocolate approx. RGB 110/82/72

Note: Slight variations in color, shade, and finish are inherent in ceramic products and thickness may vary when combining mosaics of different shapes and dimensions. Please note that the Made-To-Order mosaics are pre-assembled to facilitate installation, however, we call upon the professional expertise of the installer to make the necessary adjustments in the field.

Designer advice: Weighing up scale

Weighing up scale -
The choice of the shape dictates the scale of the mosaic. Working within a smaller space? Consider switching to a different tile shape. *Illustrated here: the same design is reinterpreted with 1" hexagons, 3/4" square and 3/4" penny rounds.

Many applications -
Our unglazed porcelain is perfect for applications throughout your space, including showers. Slip resistance surpasses the ANSI A137.1 Wet Coefficient of Friction Test.

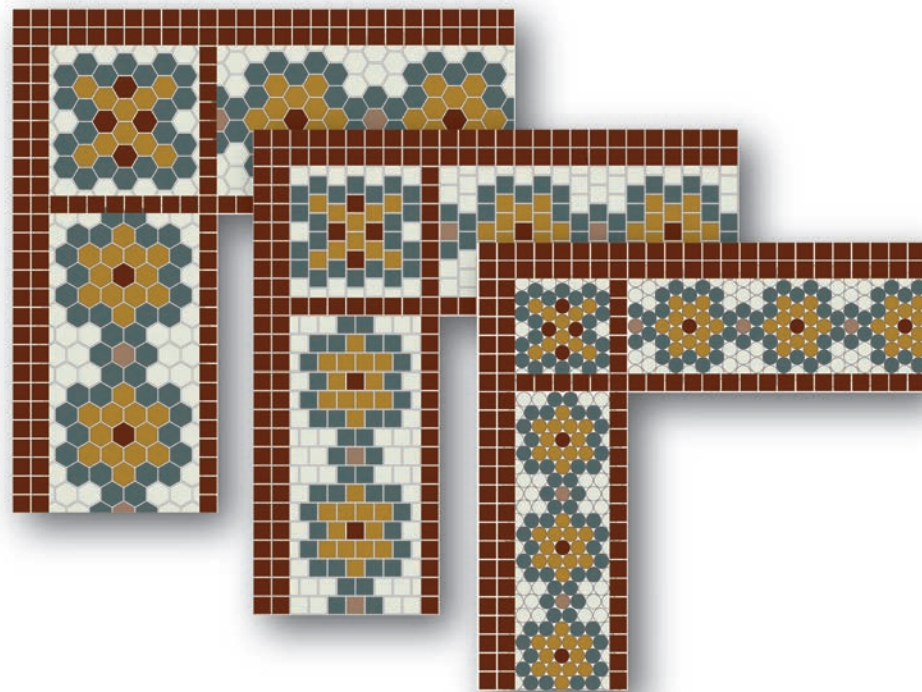

Designer Series - Custom Patterns

Step 3 - Pattern

From simple to complex, the pattern brings palette and shape together in unlimited combinations. Subway Mosaic affords the opportunity to create a fitting design for your space, whether it is modern, traditional, or something in between. The mosaic patterns shown below have adorned the floors of buildings throughout American history, from Victorian, to Mid-Century Modern, to contemporary styles. Use our color palette to add some color or spark your own design. Our team will make your sketches come to life by providing drawings for your approval and building your modules to put together on-site.

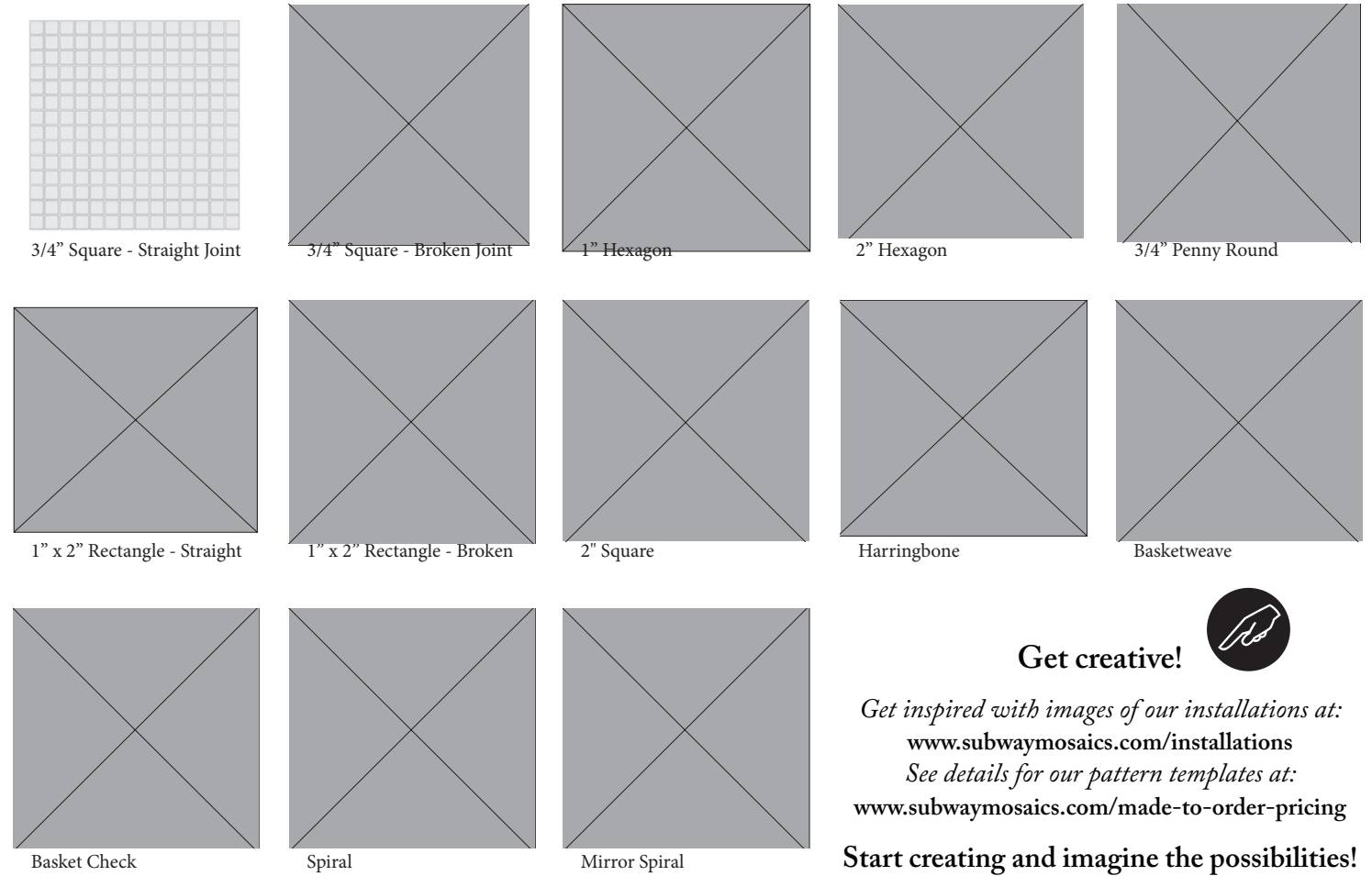

Get creative!



Get inspired with images of our installations at:
www.subwaymosaics.com/installations
See details for our pattern templates at:
www.subwaymosaics.com/made-to-order-pricing

Start creating and imagine the possibilities!

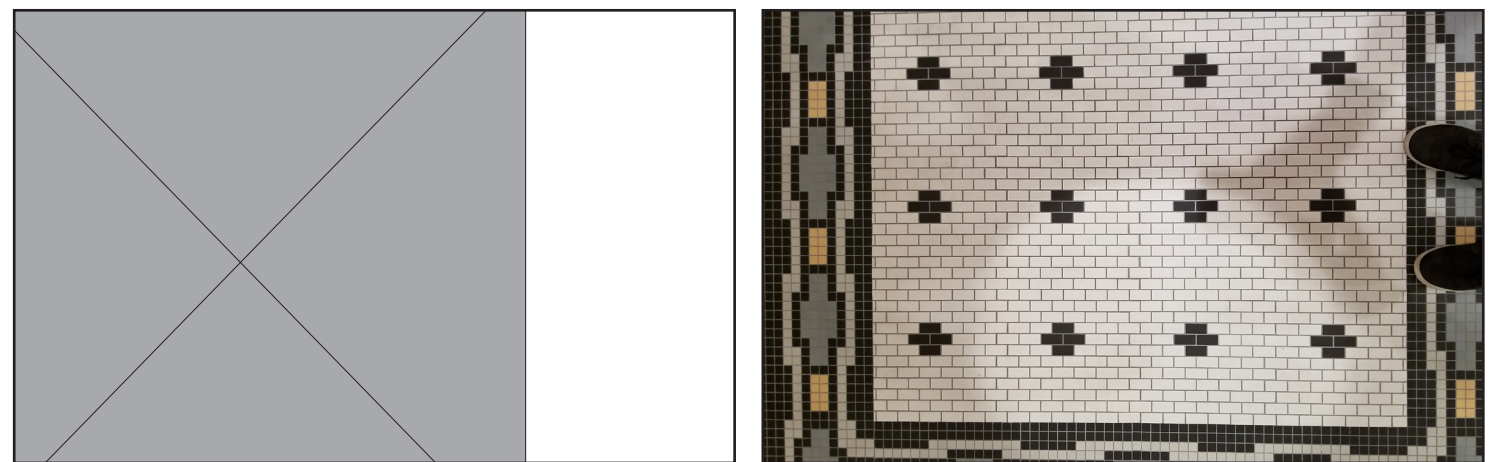

Designer Series - Popular Patterns

Pattern Borders

For a quicker alternative to our Made-to-Order mosaics, we offer our standard pattern assortment. These classic mosaic designs, comprised of a pattern border in combination with a pattern field, are found in American architectural period homes throughout history. Based on your room size, select the quantity of Straight Borders, Outside Corners and Inside Corners to complete the border in your room. Then select the quantity of Field Modules to complete your floor design. All patterns are available to order on our website and our Design Consultants are ready to assist you with any questions.

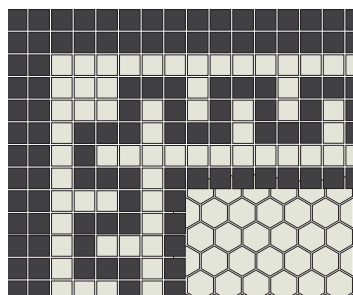

Doric Greek Key
color: Black and White
shape: 3/4" squares

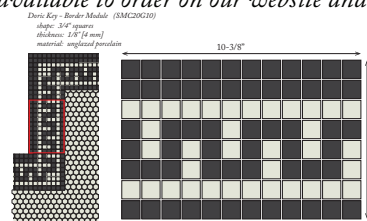

Doric Greek Key - Straight Border
color: Black and White
shape: 3/4" squares
Style# SMC20G10

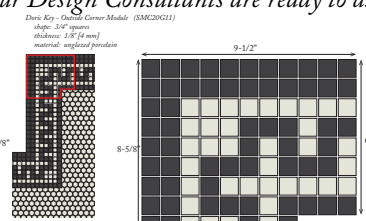

Doric Greek Key - Outside Corner
color: Black and White
shape: 3/4" squares
Style# SMC20G11

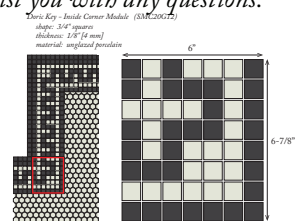

Doric Greek Key - Inside Corner
color: Black and White
shape: 3/4" squares
Style# SMC20G12

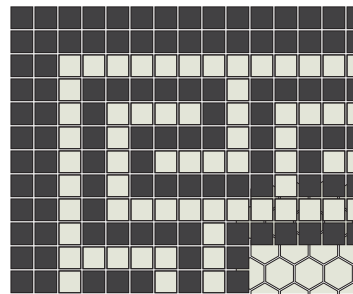

Ionic Greek Key
color: Black and White
shape: 3/4" squares + 1" hexagon field
Straight Border: SMC20G20
Outside Corner: SMC20G21
Inside Corner: SMC20G22

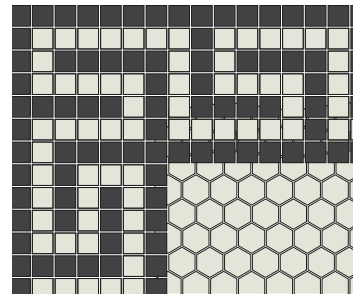

Corinthian Greek Key
color: Black and White
shape: 3/4" squares + 1" hexagon field
Straight Border: SMC20G30
Outside Corner: SMC20G31
Inside Corner: SMC20G32

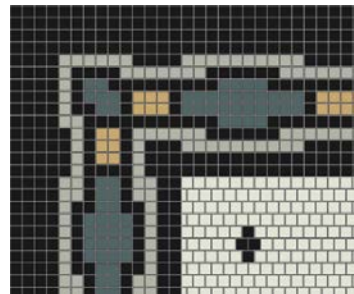

Gatsby
color: Black, White, Lt. Gray, Green and Peach
shape: 3/4" squares
Straight Border: SMPPGY0A
Outside Corner: SMPPGY01
Inside Corner: SMPPGY02

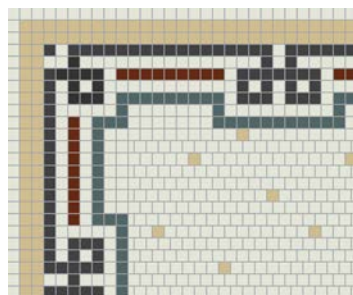

Ginko Tree
color: Black, White, Lt. Yellow, Green and Red
shape: 3/4" squares
Straight Border 1: SMPPGT0A
Straight Border 2: SMPPGT0B
Outside Corner: SMPPGT01
Inside Corner: SMPPGT02

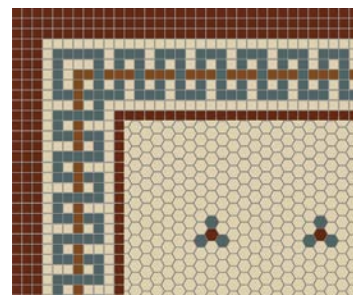

Extended Doric Key
color: Red, Cream, Green and Caramel
shape: 3/4" squares + 1" hexagon field
Straight Border: SMPPXD00
Outside Corner: SMPPXD01
Inside Corner: SMPPXD02



Details!

Dimensional drawings for all popular designs can be seen at:
www.shop.subwaymosaics.com/shop/category/popular-patterns-86

Designer Series - Popular Patterns

Pattern Fields

These Pattern Field Modules are available in combination with the Pattern Borders to complete your border style floor, or separately to have a wall-to-wall borderless style mosaic floor. All patterns are available to order on our website and our Design Consultants are ready to assist you with any questions.

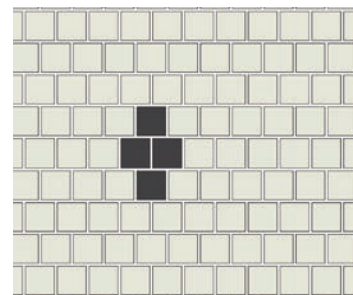

Gatsby - Field Module
color: Black and White
shape: 3/4" squares
Style# SMPPGY00

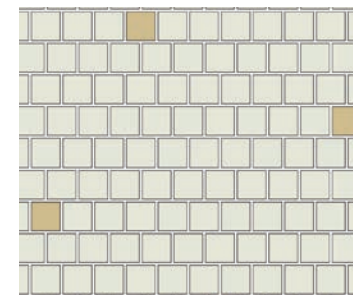

Ginko Tree - Field Module
color: White and Lt. Yellow
shape: 3/4" squares
Style# SMPPGT00

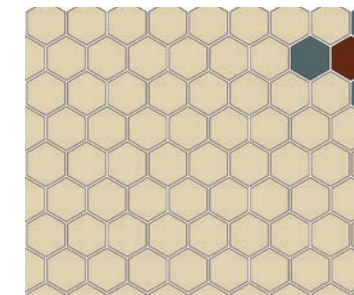

Extended Doric Key - Field Module
color: Cream, Green and Red
shape: 1" hexagon
Style# SMPPXD00



Daisy - Field Module
color: Black and White
shape: 1" hexagon
Style# SMPPDY00

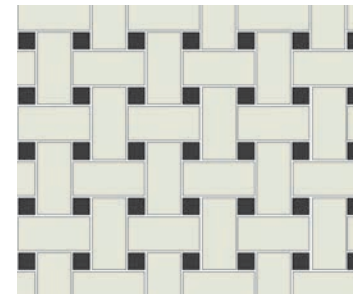

Basketweave - Field Module
color: Black and White
shape: 1/2" squares + 1"x2" rectangles
Style# SMC50BW1

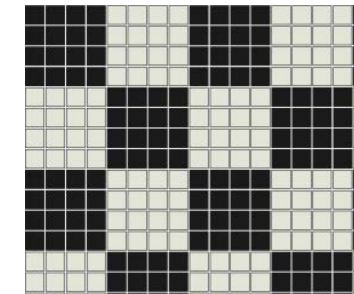

Checkerboard - Field Module
color: Black and White
shape: 3/4" squares
Style# SMC25CB1

Solid Fields

All of our Classic Field Modules are also available to order in any solid color, and ready for quick shipment. Visit our website to see all of our many options.

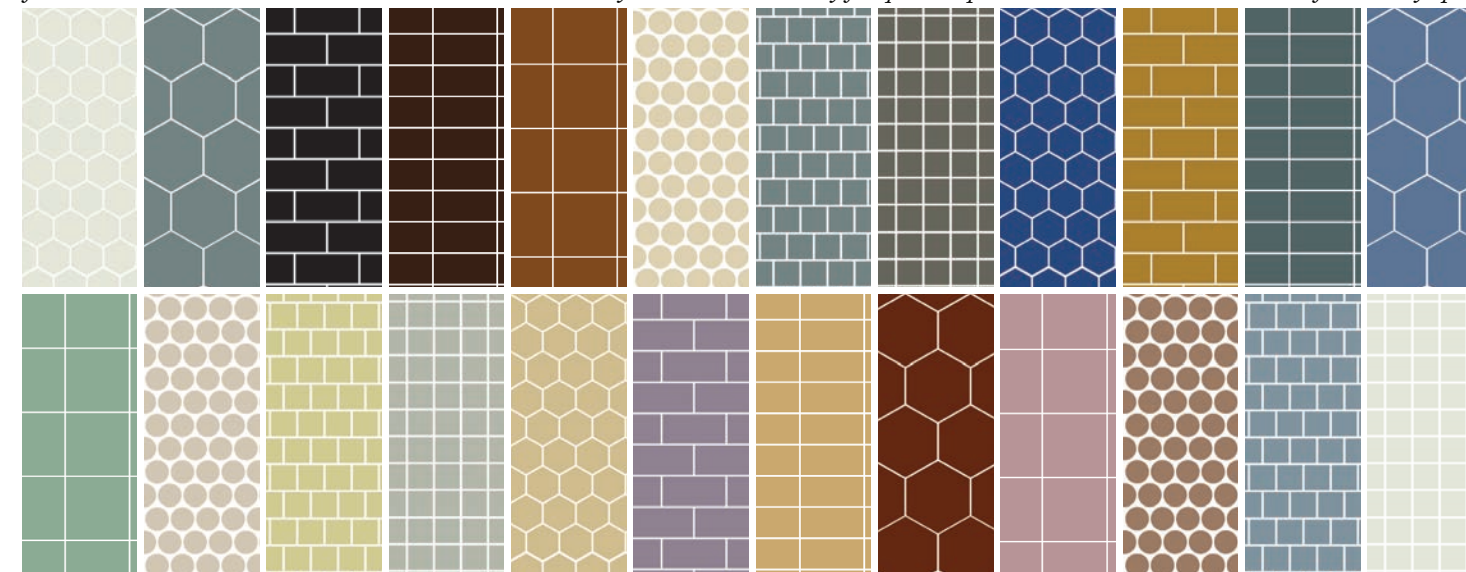

Classic Series - Custom Patterns

Step 1 - Shape

Selection of four traditional shapes.

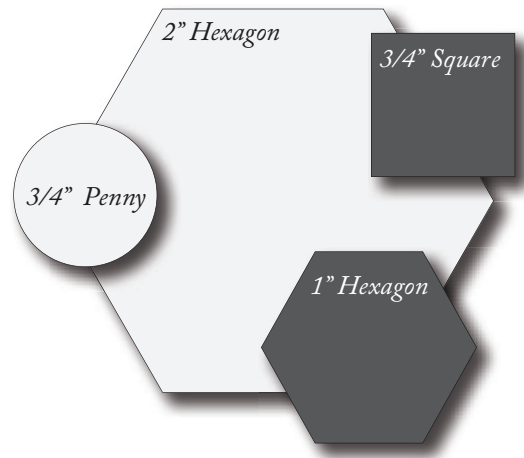

Step 2 - Color Palette

Arctic & Charcoal through-body colors in unglazed porcelain.

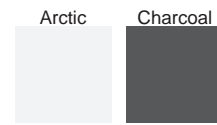

Get creative!



Get inspired with images of our installations at:
www.subwaymosaics.com/installations
 See details for our pattern templates at:
www.subwaymosaics.com/made-to-order-pricing

Start creating and imagine the possibilities!

Note: Slight variations in color, shade, and finish are inherent in ceramic products and thickness may vary when combining mosaics of different shapes and dimensions. Please note that the Made-To-Order mosaics are pre-assembled to facilitate installation, however, we call upon the professional expertise of the installer to make the necessary adjustments in the field.

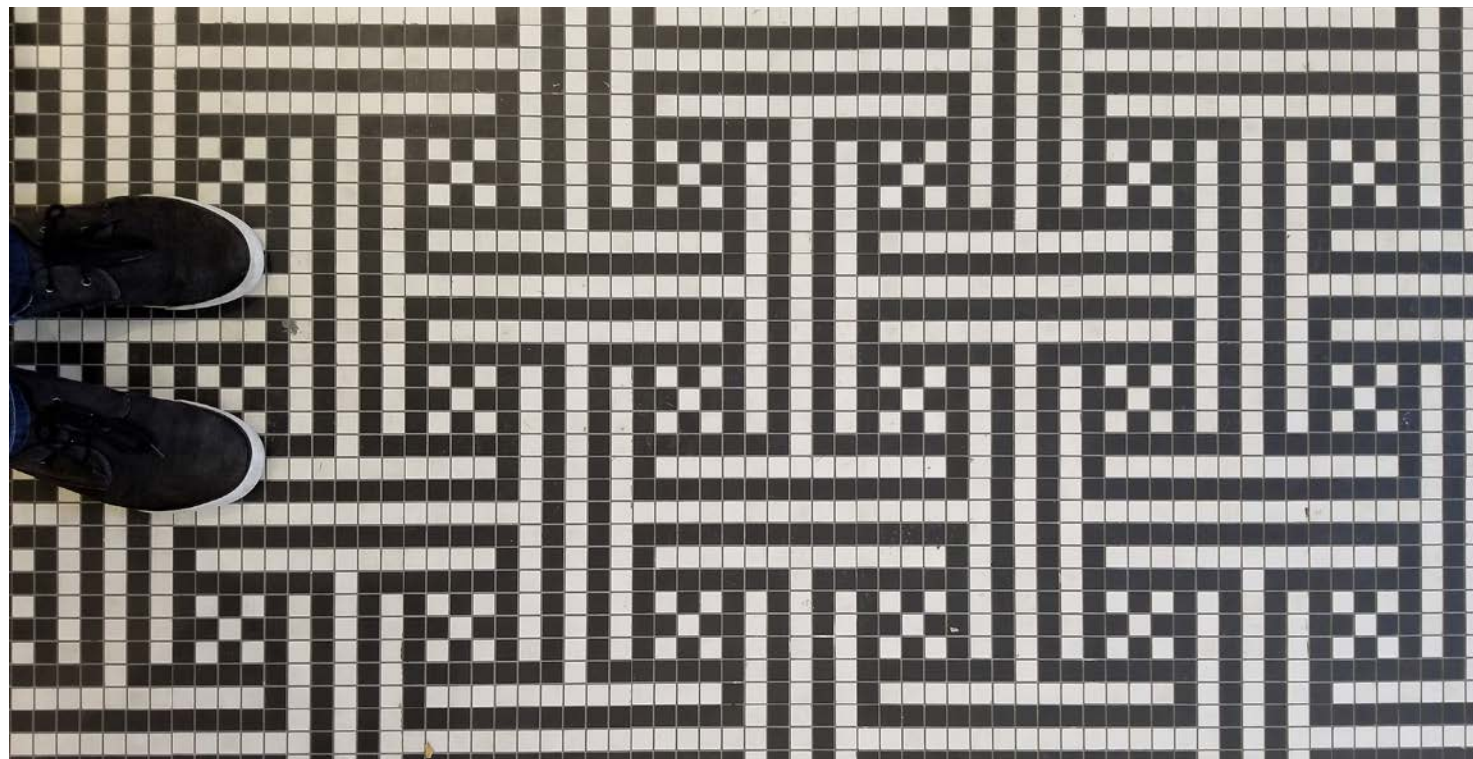

Classic Series - Custom Patterns

Step 3 - Pattern

From simple to complex, the pattern brings the shapes in Arctic and Charcoal together in unlimited combinations. Subway Mosaic affords the opportunity to create a fitting design for your space, whether it is modern, traditional, or something in between. The mosaic patterns shown below have adorned the floors of buildings throughout American history, from Victorian, to Mid-Century Modern, to contemporary styles. Our team will make your sketches come to life by providing drawings for your approval and building your modules to put together on-site.

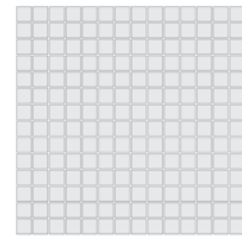

3/4" Square - Straight Joint

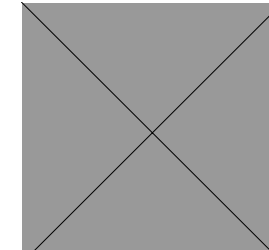

3/4" Square - Broken Joint

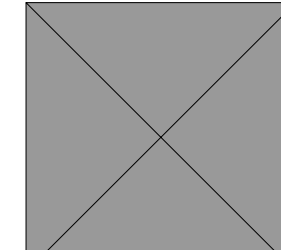

1" Hexagon

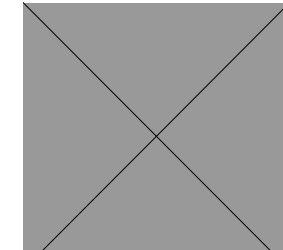

2" Hexagon

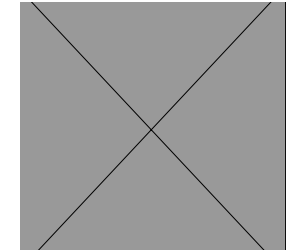

3/4" Penny Round

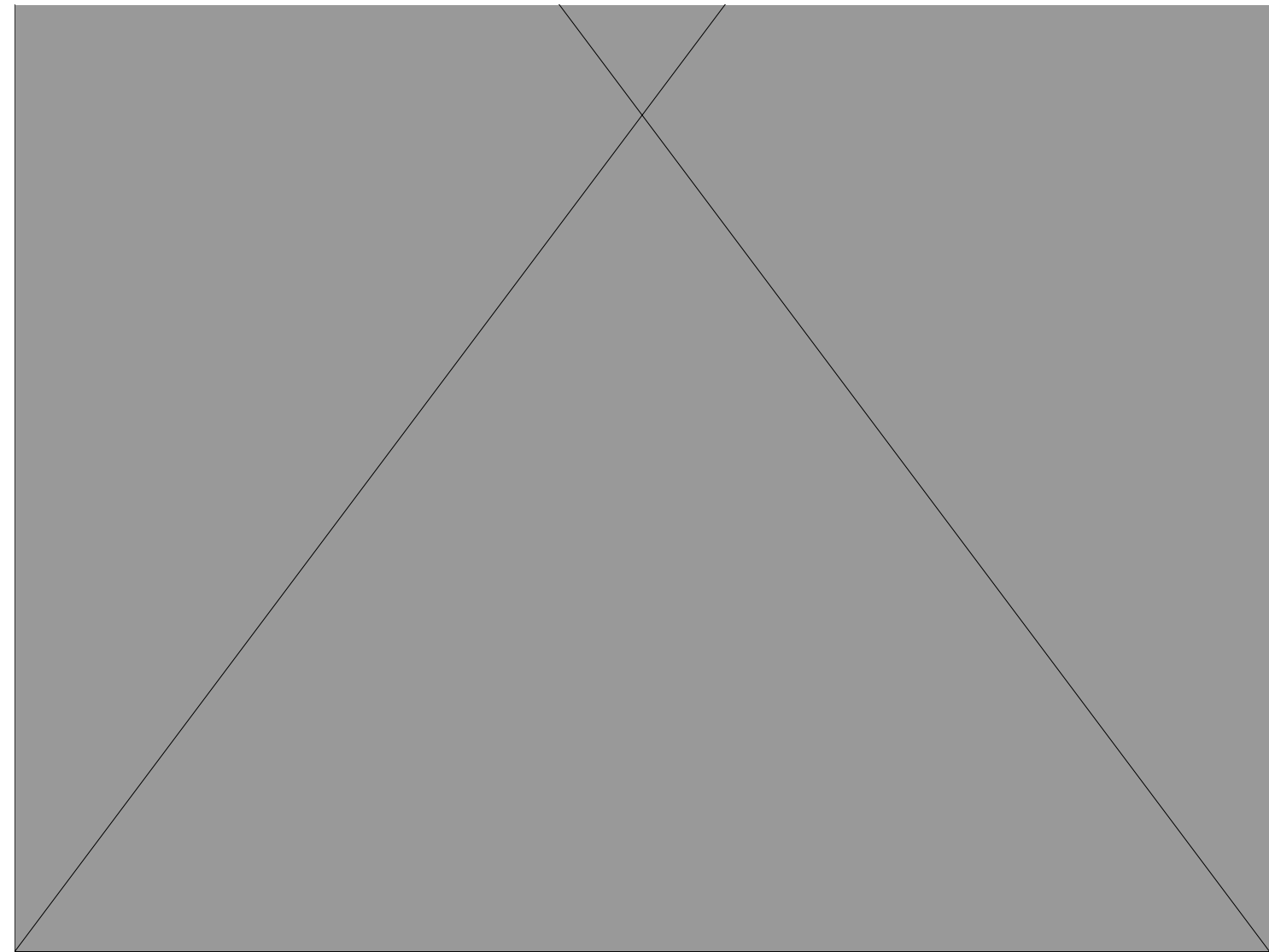

Classic Series - Popular Patterns

Pattern Borders

For a quicker alternative to our Made-to-Order mosaics, we offer our standard pattern assortment. These classic mosaic designs, comprised of a pattern border in combination with a pattern field, are found in American architectural period homes throughout history. Based on your room size, select the quantity of Straight Borders, Outside Corners and Inside Corners to complete the border in your room. Then select the quantity of Field Modules to complete your floor design. All patterns are available to order on our website and our Design Consultants are ready to assist you with any questions.

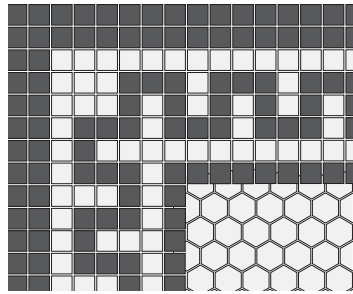

Doric Greek Key
color: Charcoal & Arctic
shape: 3/4" squares

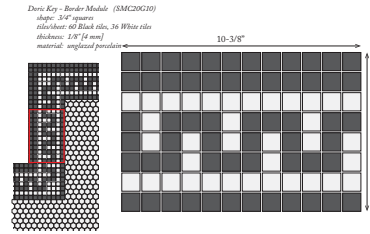

Doric Greek Key - Straight Border
color: Charcoal & Arctic
shape: 3/4" squares
Style# SMC20G10

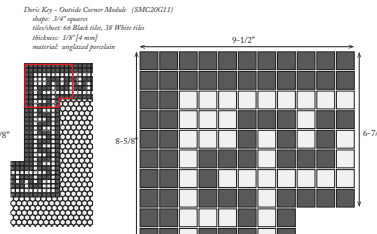

Doric Greek Key - Outside Corner
color: Charcoal & Arctic
shape: 3/4" squares
Style# SMC20G11

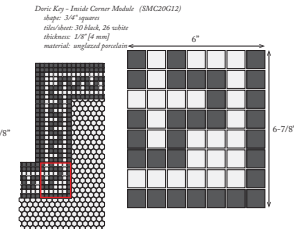

Doric Greek Key - Inside Corner
color: Charcoal & Arctic
shape: 3/4" squares
Style# SMC20G12

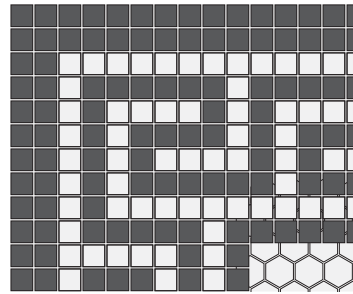

Ionic Greek Key
color: Charcoal & Arctic
shape: 3/4" squares + 1" hexagon field
Straight Border: SMC20G20
Outside Corner: SMC20G21
Inside Corner: SMC20G22

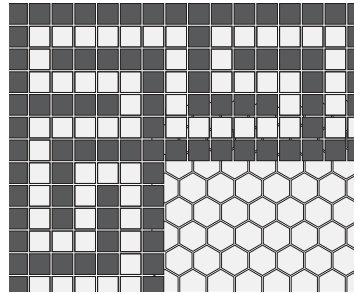

Corinthian Greek Key
color: Charcoal & Arctic
shape: 3/4" squares + 1" hexagon field
Straight Border: SMC20G30
Outside Corner: SMC20G31
Inside Corner: SMC20G32



Details!

Dimensional drawings for all popular designs can be seen at:
www.shop.subwaymosaics.com/shop/category/popular-patterns-86



Classic Series - Popular Patterns

Pattern Fields

These Pattern Field Modules are available in combination with the Pattern Borders to complete your border style floor, or separately to have a wall-to-wall borderless style mosaic floor. All patterns are available to order on our website and our Design Consultants are ready to assist you with any questions.

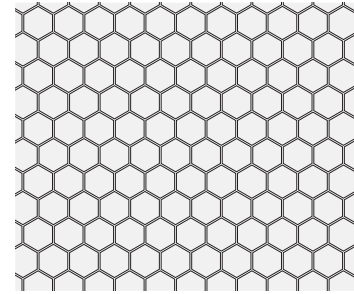

Greek Key - Field Module
color: Arctic
shape: 1" hexagon
Style# SMM25HE4

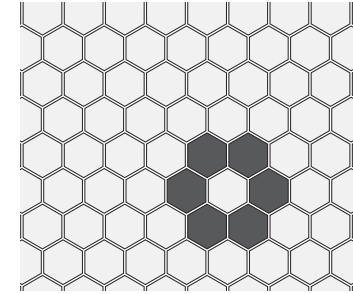

Daisy - Field Module
color: Charcoal & Arctic
shape: 1" hexagon
Style# SMPPDY00

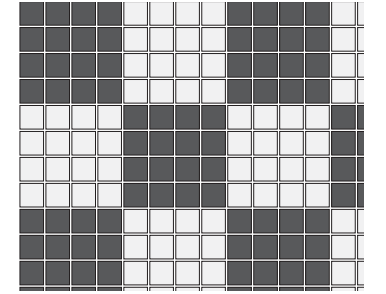

Checkerboard - Field Module
color: Charcoal & Arctic
shape: 3/4" squares
Style# SMC25CB1



Solid Fields

All of our Classic Field Modules are also available to order in solid color, and ready for quick shipment. Visit our website to see all of our many options.



Font Series - Custom Pattern

Are you ready to take your design to the next level? Our wide range of made-to-order fonts are perfect for authenticating the period home or adding interest to a modern space.

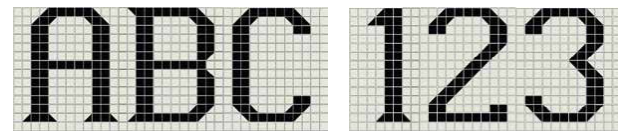

A.M.

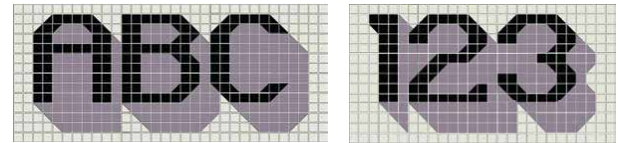

BLOCK SHADOW

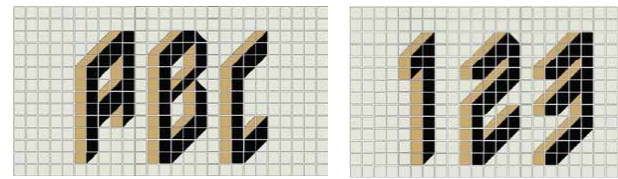

CALIFORNIA

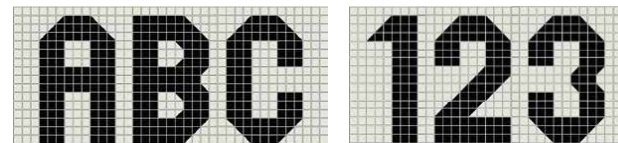

CAP BLOCK

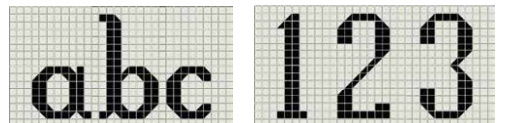

FINCH

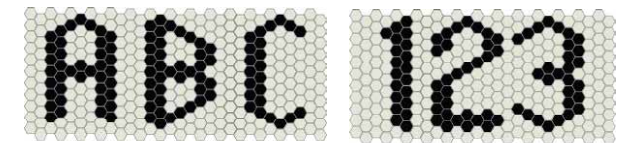

GOOD

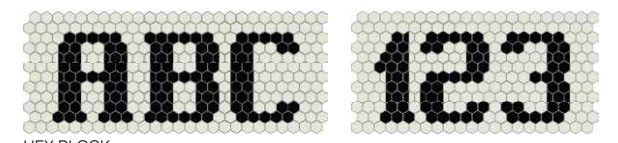

HEX BLOCK

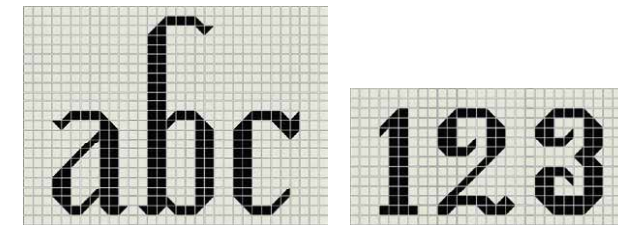

HISTORIC No.1

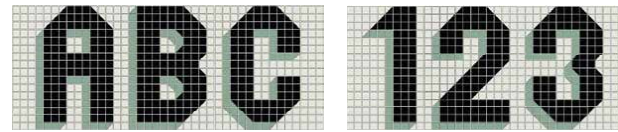

3D CAP BLOCK

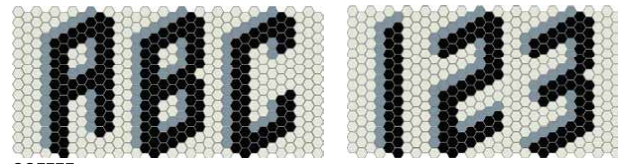

COFFEE

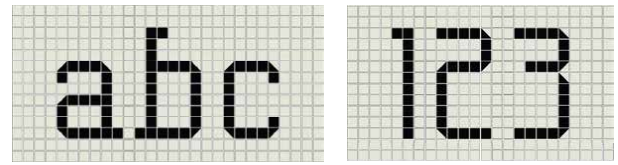

DATA

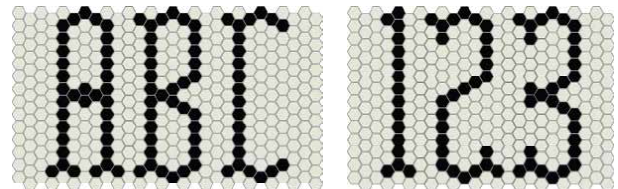

D-LUX

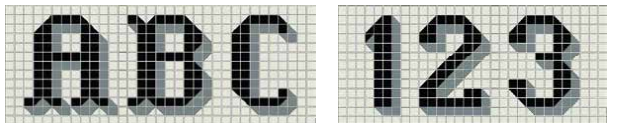

HISTORIC No.2

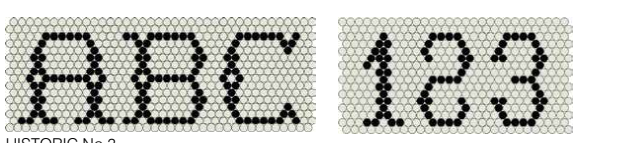

HISTORIC No.3

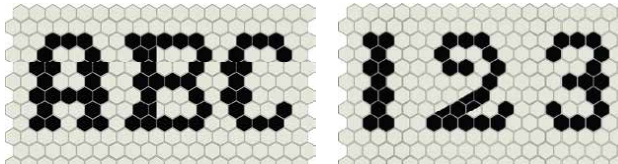

HISTORIC No.4

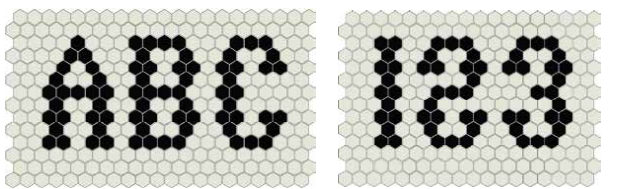

LAUBER

Font Series - Custom Pattern

If you have a project, we can make it happen. Contact one of our design consultants today to make your vision become a reality.

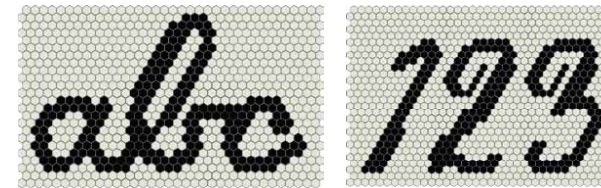

LC SCRIPT

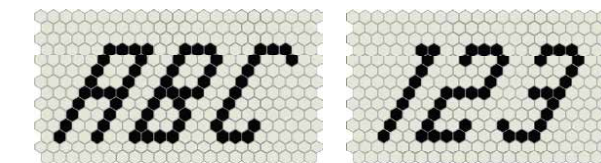

LEAN

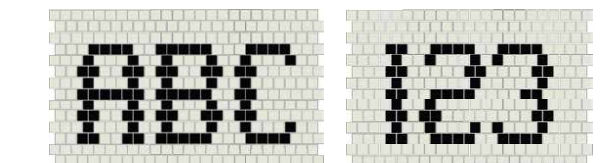

NEWTON

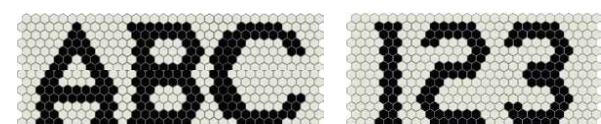

PALMER

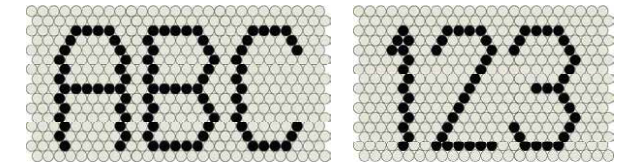

PENNY DROP

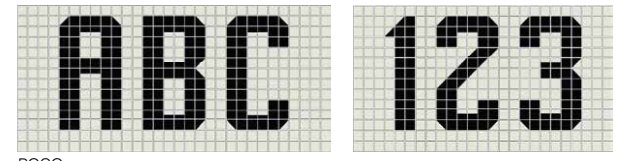

POCO

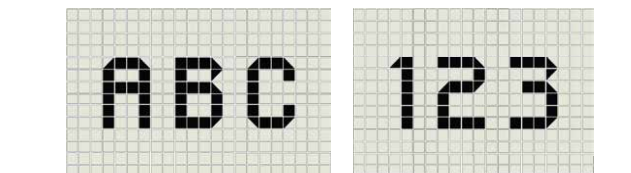

SHALLOW

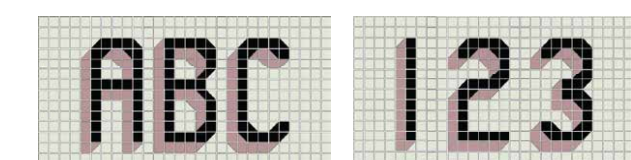

STEP

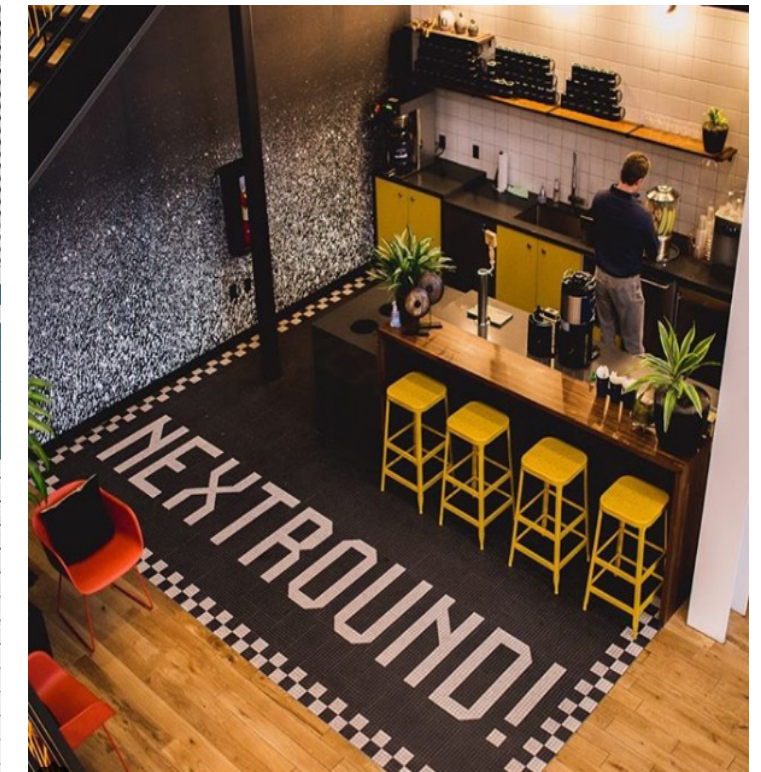



prt#:SCQ121V1

WWW.HERITAGETILE.COM

info@heritagetile.com



Tel: 888-387-3280